

# PAN3011

## IoT Solution Module

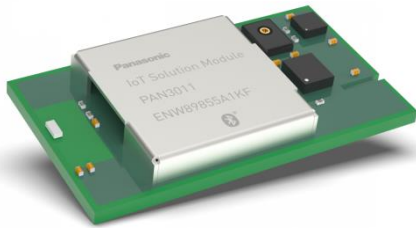

### [OVERVIEW]

Creating IoT Solution Modules like the PAN3011, that clearly contribute to cutting down time to market in development processes in these rather fast paced times of innovation and automatization has been the clear priority for Panasonic Industry. Being based on and inspired by the ST BlueTile (STEVAL-BCN002V1B) multi-sensor development kit, customers are now able to test and evaluate their ideas easily and bring new IoT products appropriately fast and at a reduced BOM to the markets.

The IoT Solution Module features ST's latest BlueNRG Bluetooth Low Energy (BLE) 5.0 system-on-chip (SoC) paired with inertial, audio and magnetic sensors. The onboard sensors enable the cost-effective delivery of a broad range of compact and valuable IoT applications for smart factory, smart home and smart life scenarios.

The combination of accelerometer, gyroscope, magnetometer and audio sensors in an efficient low-power design with Bluetooth communications enables OEM customers to dramatically slash time-to-market and reduce design expense and complexity using certified modules.

### [FEATURES]

- **BlueNRG-2**  
Bluetooth Low Energy single-mode system-on-chip
- **LSM6DSO**  
3D accelerometer and 3D gyroscope, iNEMO 6DoF inertial module, ultra-low power and high accuracy
- **LIS2MDL**  
magnetic sensor, digital output, 50 gauss magnetic field dynamic range, ultra-low power, high performance, 3-axis magnetometer
- **MP34DT05-A**  
MEMS audio sensor omnidirectional digital microphone, 64 dB SNR, -26 dBFS sensitivity, top-port, 122.5 dB SPL AOP

## [BLOCK DIAGRAM]

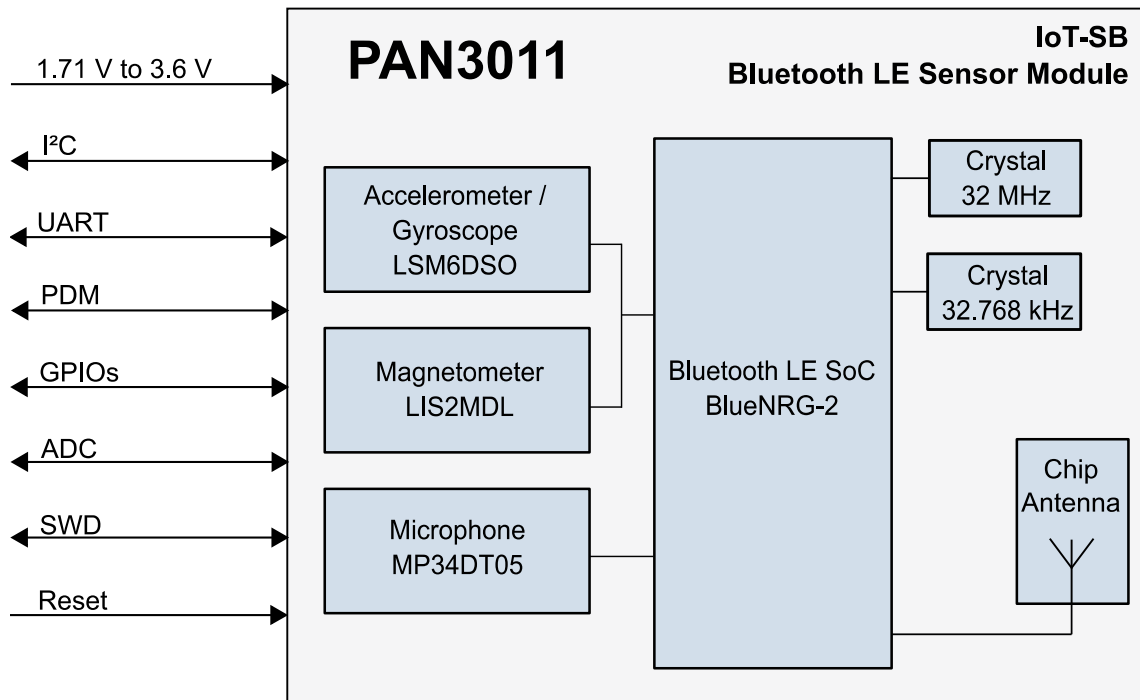

## [BLUETOOTH SoC]

- ST's latest BlueNRG Bluetooth Low Energy (BLE) 5.0 system-on-chip (SoC)
- Single-core, ultra-low-power 32-bit ARM® Cortex®-M0 core architecture up to 32 MHz
- 256 KB of embedded Flash memory, 24 KB of ultra-low-leakage RAM (with full data retention)
- Interfaces: I2C, UART, PDM, GPIO, ADC, SWD

## [TECHNICAL CHARACTERISTICS]

- Surface mount type dimensions: 25.0 mm x 14.0 mm x 3.0 mm
- Typical Rx Sensitivity: -88 dBm
- Typical Tx output power: +8 dBm
- Power consumption:
  - Tx: 17 mA @8dBm (3V)
  - Rx: 10 mA
  - Sleep: 10µA
- Voltage range: 1.71 V to 3.6 V
- Temperature range: -40 °C to 85 °C