

# PAN3013

## IoT Solution Module

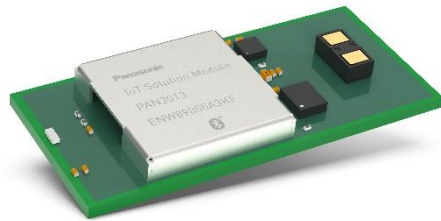

### [OVERVIEW]

Creating IoT Solution Modules like the PAN3013, that clearly contribute to cutting down time to market in development processes in these rather fast paced times of innovation and automatization has been the clear priority for Panasonic Industry. Being based on and inspired by the ST BlueTile (STEVAL-BCN002V1B) multi-sensor development kit, customers are now able to test and evaluate their ideas easily and bring new IoT products appropriately fast and at a reduced BOM to the markets.

The PAN3013 includes next to a Bluetooth 5 SoC a Time-of-Flight sensor, a magnetometer and an accelerometer and gyroscope. With its selection of sensors, the PAN3013 is a perfect fit for applications in the field of smart industry respective robotics, obstacle detection, gesture recognition or surveillance

While guaranteeing the highest quality and all required certifications, the collaboratively launched Panasonic Industry IoT solution module family will temporarily serve the customer's needs in efficiently bringing new ideas to life.

### [FEATURES]

- **BlueNRG-2**  
Bluetooth Low Energy single-mode system-on-chip
- **VL53L1X**  
Long distance ranging Time-of-flight sensor, up to 400cm distance measurement, up to 50Hz ranging frequency
- **LSM6DSO**  
3D accelerometer and 3D gyroscope, iNEMO 6DoF inertial module, ultra-low power and high accuracy
- **LIS2MDL**  
magnetic sensor, digital output, 50 gauss magnetic field dynamic range, ultra-low power, high performance, 3-axis magnetometer



Dr. Sara Ghaemi

Team Leader IoT

[Sara.ghaemi@eu.panasonic.com](mailto:Sara.ghaemi@eu.panasonic.com)

+49 152 56882234

## [BLOCK DIAGRAM]

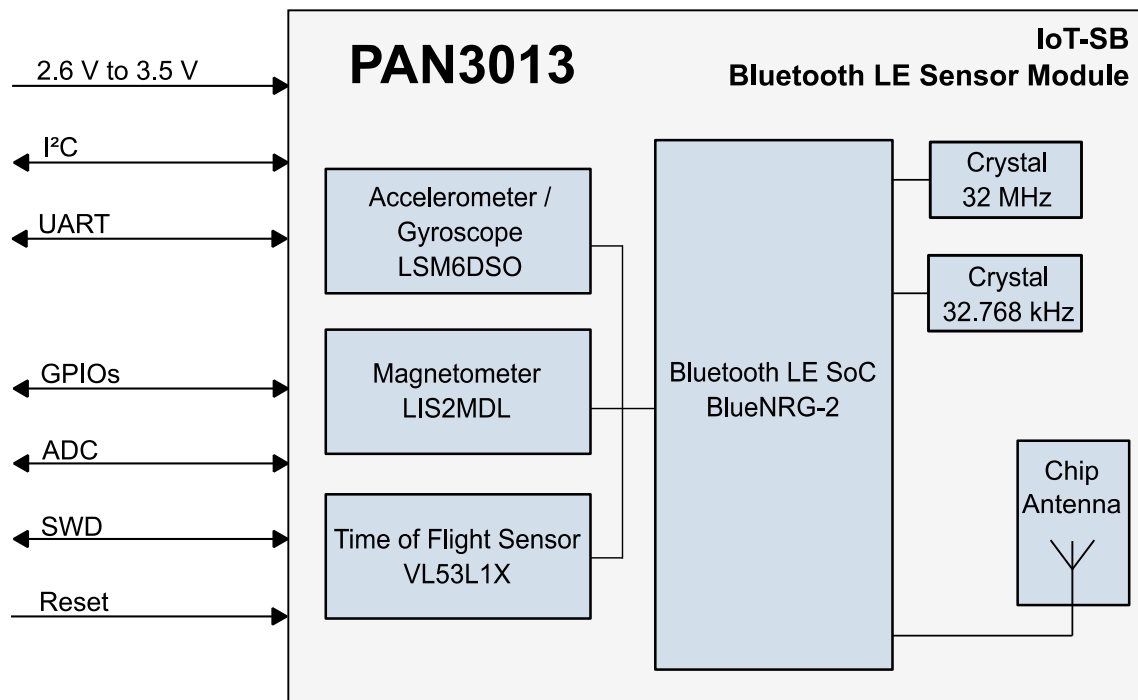

## [BLUETOOTH SoC]

- ST's latest BlueNRG Bluetooth LE 5 SoC
- Single-core, ultra-low-power 32-bit ARM® Cortex®-M0 core architecture up to 32 MHz
- 256 KB of embedded Flash memory, 24 KB of ultra-low-leakage RAM (with full data retention)
- Interfaces: I2C, UART, GPIO, ADC, SWD

## [TECHNICAL CHARACTERISTICS]

- Surface mount type dimensions: 31.0 mm x 14.0 mm x 3.0 mm
- Typical Rx Sensitivity: -88 dBm
- Typical Tx output power: +8 dBm
- Power consumption:
  - Tx: 32 mA @8dBm (3V)
  - Rx: 25 mA
  - Sleep: 11µA
- Voltage range: 2.6 V to 3.5 V
- Temperature range: -20 °C to 85 °C