

PROGRAMMABLE CONTROLLER

FP $\Sigma$  CC-Link Slave Unit

FPO CC-Link Slave Unit

# Technical Manual

---

# Safety Precautions

Observe the following notices to ensure personal safety or to prevent accidents.  
To ensure that you use this product correctly, read this User's Manual thoroughly before use.  
Make sure that you fully understand the product and information on safety.  
This manual uses two safety flags to indicate different levels of danger.

## **WARNING**

**If critical situations that could lead to user's death or serious injury is assumed by mishandling of the product.**

- Always take precautions to ensure the overall safety of your system, so that the whole system remains safe in the event of failure of this product or other external factor.
- Do not use this product in areas with inflammable gas. It could lead to an explosion.
- Exposing this product to excessive heat or open flames could cause damage to the lithium battery or other electronic parts.

## **CAUTION**

**If critical situations that could lead to user's injury or only property damage is assumed by mishandling of the product.**

- To prevent excessive exothermic heat or smoke generation, use this product at the values less than the maximum of the characteristics and performance that are assured in these specifications.
- Do not dismantle or remodel the product. It could cause excessive exothermic heat or smoke generation.
- Do not touch the terminal while turning on electricity. It could lead to an electric shock.
- Use the external devices to function the emergency stop and interlock circuit.
- Connect the wires or connectors securely.  
The loose connection could cause excessive exothermic heat or smoke generation.
- Do not allow foreign matters such as liquid, flammable materials, metals to go into the inside of the product. It could cause excessive exothermic heat or smoke generation.
- Do not undertake construction (such as connection and disconnection) while the power supply is on. It could lead to an electric shock.

# Copyright / Trademarks

- This manual and its contents are copyrighted.
- You may not copy this manual, in whole or part, without written consent of Panasonic Industry Co., Ltd.
- Windows is a registered trademark of Microsoft Corporation in the United States and other countries.
- All other company names and product names are trademarks or registered trademarks of their respective owners.

# Table of Contents

---

## Precautions before Using CC-link Slave Unit

<b>1 Functions of CC-Link Slave Unit</b> .....	<b>1</b>
1.1 Unit Functions .....	1
1.2 Unit Type .....	1
1.3 Unit Connection .....	2
<b>2 Part Names and Functions</b> .....	<b>3</b>
2.1 Part Names and Functions .....	3
<b>3 Allocation of Input/Output and Shared Memory</b> .....	<b>6</b>
3.1 FP $\Sigma$ CC-Link Slave Unit .....	6
3.2 FP0 CC-Link Slave Unit .....	10
<b>4 Wiring</b> .....	<b>12</b>
<b>5 If an Error Occurs</b> .....	<b>13</b>
5.1 Troubleshooting .....	13
5.2 ERR/ALARM LED .....	14
<b>6 Specifications</b> .....	<b>15</b>
6.1 Specifications .....	15
6.2 Dimensions .....	17

# Precautions before Using CC-Link Slave Unit

---

## - Mounting plate

- Note that the types of mounting plates used for FP  $\Sigma$  and FP0 are different.

Unit name (including CPU)	Mounting plate to be used	
FP $\Sigma$ CC-Link slave unit	Slim type 30 FP0 mounting plate	AFP0811
FP0 CC-Link slave unit	Slim type FP0 mounting plate	AFP0803

## - Installation of CC-Link slave unit

- Normally, any unit cannot be installed on the right side of the FP0 CC-Link slave unit.
- To assure the measurement accuracy, it is not recommended for any unit to be installed on the right side of the FP0 thermocouple unit. When the FP0 CC-Link slave unit is used together with the FP0 thermocouple unit in a system, FP0 CC-Link slave unit can be on the right side of the FP0 thermocouple unit.



**Reference:** Measurement accuracy when the FP0 thermocouple unit is used together with the FP0 CC-Link slave unit in a system <1.3 Unit Connection>

## - CC-Link Partner Association

1F Chusanren Bldg. 3-12-13 Shirakabe, Higashi-ku, Nagoya 461-0011, JAPAN

Phone: +81-52-936-6050, Fax: +81-52-936-6005

E-mail: [cc-link@post0.mind.ne.jp](mailto:cc-link@post0.mind.ne.jp)

HP: (English) : <https://www.cc-link.org/eng/index.html>

(Japanese): <https://www.cc-link.org>

# 1 Functions of CC-Link Slave Unit

## 1.1 Unit Functions

1. Data can be exchanged between the CC-Link master station and FP0/ FP  $\Sigma$  slave station.
2. **Communication speed:** 157k to 10Mbit/s
3. **Communication distance:** 100 m to 1200m
4. **Interface:** RS485
5. **I/O points:** 16I/16O to 80I/80O (FP0 CC-Link slave unit)  
: 16I/16O to 112I/112O (FP  $\Sigma$  CC-Link slave unit)

## 1.2 Unit Type

### - CC-Link slave unit

Name	Type	I/O points <sup>Note1</sup>	Number of data points exchanged with CC-Link master station <sup>Note3</sup>	Product No.
FP $\Sigma$ CC-Link slave unit	FPG-CCLS	256 points Max. (Input: 128) (Output: 128)	224 points Max. (Input: 112, Output 112) 16-word data read/write (Max.)	AFP07943
FP0 CC-Link slave unit	FP0-CCLS	192 points Max. (Input: 96) (Output: 96)	32 points Max. (Input: 16, Output 16) 4-word data read/write (Max.)	AFP07943

Note 1: Occupied number of I/O points in the FP  $\Sigma$ /0 expansion area

The number of the occupied I/O points varies depending on the switch setting (for FP  $\Sigma$  CC-Link slave unit) and the location of the expansion unit (for FP0 CC-Link slave unit).

Note 2: FP0 CC-Link slave unit does not have a connector for the next expansion unit. One FP0 CC-Link slave unit should be installed on the extremely right in the expansion position.

Note 3: All the data for the FP0 CC-Link slave unit are allocated to the I/O area.



**Reference:** <3 Allocation of Input/Output and Shared Memory>

# 1.3 Unit Connection

**- Limitations in unit number and position**

**- FP  $\Sigma$  CC-Link slave unit**

Up to 4 expansion units (including other FP  $\Sigma$  expansion unit and FP  $\Sigma$  high-performance unit) can be installed.

**- FP0 CC-Link slave unit**

Up to 3 expansion units (including other FP0 expansion unit and FP0 high-performance unit) can be installed. However, two or more FP0 CC-Link slave units cannot be installed in a system.

A unit cannot be installed on the right of the FP0 CC-Link slave unit, because the unit does not have the expansion connector on its right.

**- When using the CC-Link slave unit with the FP0 thermocouple unit**

In the FP0 thermocouple unit manual, it is not recommended for any unit to be installed on the right side of the FP0 thermocouple unit to assure the measurement accuracy. However, the FP0 CC-Link slave unit can be installed on the right of the FP0 thermocouple unit. In this case, the accuracy for the FP0 thermocouple unit is as shown in the table below.

Thermocouple used		Standard specifications	When CC-Link slave unit with the thermocouple unit
K, J, T		0.8 °C	2 °C
R	0 to 99.9 °C	3 °C	6 °C
	100 to 299.9 °C	2.5 °C	5 °C
	300 to 1500 °C	2 °C	4 °C

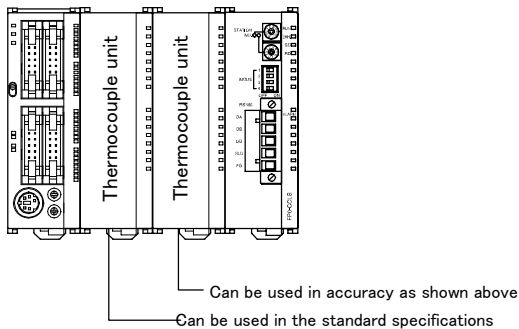

**Reference:** <FP0 Thermocouple Unit Technical Manual (ARCT1F366E)>

# 2 Part Names and Functions

## 2.1 Part Names and Functions

### - FP $\Sigma$ CC-Link slave unit (FPG-CCLS) AFPG7943

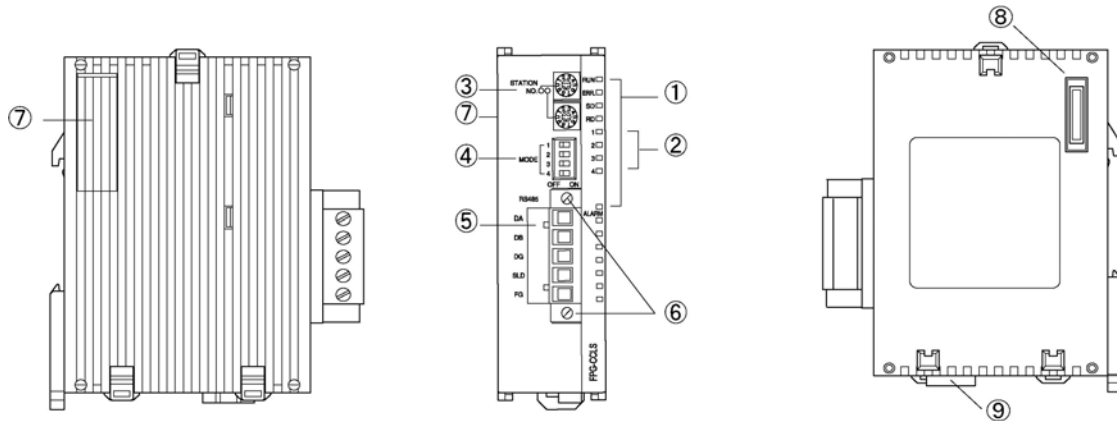

### - FP0 CC-Link slave unit (FP0-CCLS) AFP07943

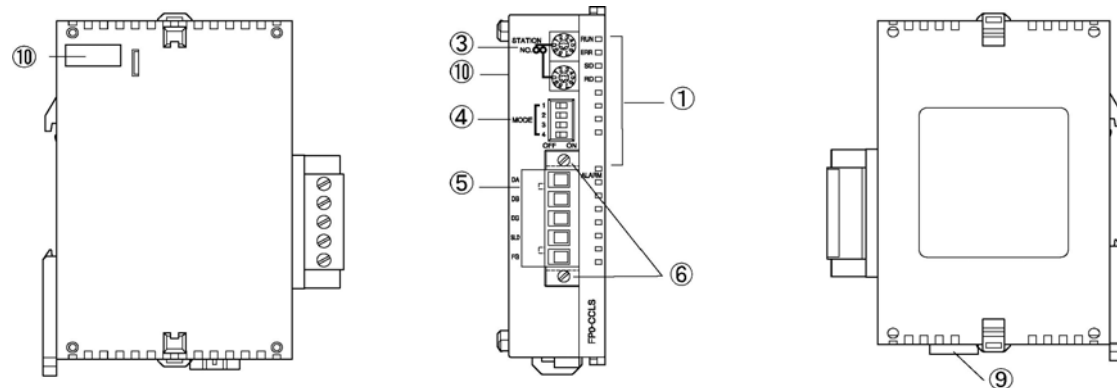

- ① Operating monitor LEDs
- ② Number of occupied stations (Available only for FP  $\Sigma$  CC-Link slave unit)
- ③ Station No. selector switch
- ④ Baud rate selection switch
- ⑤ Transmission line (RS485) terminal block
- ⑥ Fixing screw for a detachable terminal block
- ⑦ Expansion connector occupied station No. selection switch  
(Available only for FP  $\Sigma$  CC-Link slave unit)
- ⑧ Expansion connector (Available only for FP  $\Sigma$  CC-Link slave unit)
- ⑨ Power supply connector (24V DC)
- ⑩ Expansion connector (Available only for FP0 CC-Link slave unit)

### ① Operating monitor LEDs

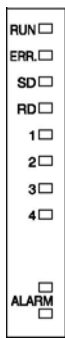

- RUN : Turns ON when communication is normal.
- ERR : Turns ON when a switch setting error has occurred.
- SD : Turns ON when data is being transmitted.
- RD : Turns ON when data is being received.
- 1 : Flashes when a switch setting is changed while the power is ON.
- 2
- 3
- 4
- ALARM : Turns ON when a hardware error has occurred.  
Turns ON when a station No. setting error has occurred.

### ② Number of occupied stations (Available only for FP $\Sigma$ CC-Link slave unit)

1 to 4 LEDs: Number of occupied stations turns ON.

### ③ Station No. selector switch

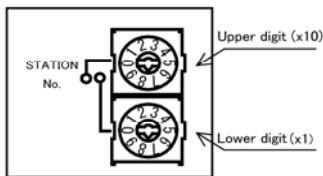

1 to 64: Station No.  
0, and 65 to 99: Setting error

### ④ Baud rate selection switch

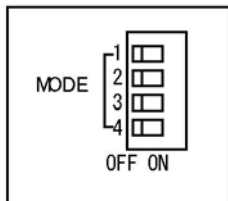

SW. No.	Baud rate				
	156k	625k	2.5M	5M	10M
1	OFF	ON	OFF	ON	OFF
2	OFF	OFF	ON	ON	OFF
3	OFF	OFF	OFF	OFF	ON
4	OFF: Input data is cleared when communication halts. <sup>Note)</sup>				
	ON: Input data is held when communication halts. <sup>Note)</sup>				

Note: FP0/FP  $\Sigma$  input data (output data from the master station)

### ⑤ Transmission line (RS485) terminal block

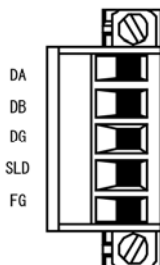

Used for connecting the CC-Link cables.  
The terminals SLD and FG are connected each other inside the CC-Link unit.



⑥ Fixing screw for a detachable terminal block

⑦ Expansion connector occupied station No. selection switch (Available only for FP  $\Sigma$  CC-Link slave unit)

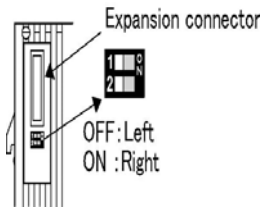

SW. No.	Number of occupies station			
	1 station	2 stations	3 stations	4 stations
1	ON	OFF	ON	OFF
2	ON	ON	OFF	OFF

Note: These switch settings are available only for FP  $\Sigma$  CC-Link slave unit.

⑧ Expansion connector (Available only for FP  $\Sigma$  CC-Link slave unit)

⑨ Power supply connector (24V DC)

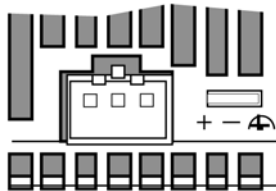

- Supply 24V DC power.  
Use the provided power supply cable for connection.
- Power used for the transmission line drive
- FG terminals of the power supply connector and transmission line terminal block are not connected in the CC-Link unit.
- Isolated from the power for the control unit.

⑩ Expansion connector (Available only for FP0 CC-Link slave unit)

# 3 Allocation of Input/Output and Shared Memory

## 3.1 FP $\Sigma$ CC-Link Slave Unit

### Communication with FP $\Sigma$ control unit

In the CC-Link slave unit, CC-Link remote input/output is allocated to the I/O area, and CC-Link remote register is allocated to the shared memory area. The number of remote words varies depending on the CC-Link station No. settings (1 to 4 stations).

Additionally, I/O allocation and shared memory slot No. depend on the location to be installed.

- Remote input/output points per station: input 32 points, output 32 points

- Remote register per station: 4 words for read, 4 words for write



**Reference:** <3.1.1 Expansion Unit I/O Allocation>

Remote input/output: Automatic update by the I/O refresh instruction

Remote register: Executed by the shared memory READ/WRITE instructions (F150 and F151)

### Slot No.

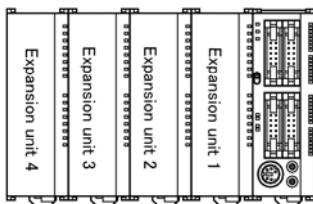

FP $\Sigma$ expansion unit No. <sup>Note)</sup>	1	2	3	4
Shared memory slot No.	0	1	2	3

Note: The expansion units closer to the control unit have the lower expansion unit number. (Expansion unit 1, 2, 3 and 4 in the diagram on the left)

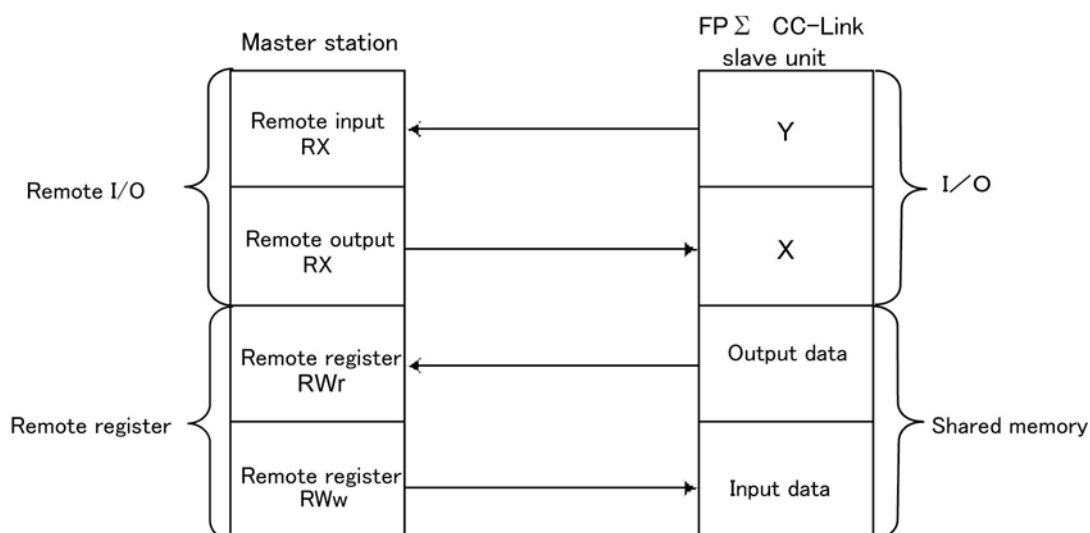

## 3.1.1 Expansion Unit I/O Allocation

### Remote input (FP $\Sigma$ side output)

No. of occupied stations	Area	Points	FP $\Sigma$ CC-Link I/O (installation position) <sup>Note 2</sup>				CC-Link master remote I/O
			Expansion unit 1	Expansion unit 2	Expansion unit 3	Expansion unit 4	
1	User area	16	Y100-Y10F	Y180-Y18F	Y260-Y26F	Y340-Y34F	RX00-RX0F
	System area	16	Y110-Y11F	Y190-Y19F	Y270-Y27F	Y350-Y35F	RX10-RX1F
2	User area	48	Y100-Y12F	Y180-Y20F	Y260-Y28F	Y340-Y36F	RX00-RX2F
	System area	16	Y130-Y13F	Y210-Y21F	Y290-Y29F	Y370-Y37F	RX30-RX3F
3	User area	80	Y100-Y14F	Y180-Y22F	Y260-Y30F	Y340-Y38F	RX00-RX4F
	System area	16	Y150-Y15F	Y230-Y23F	Y310-Y31F	Y390-Y39F	RX50-RX5F
4	User area	112	Y100-Y16F	Y180-Y24F	Y260-Y32F	Y340-Y40F	RX00-RX6F
	System area	16	Y170-Y17F	Y250-Y25F	Y330-Y33F	Y410-Y41F	RX70-RX7F

### Remote output (FP $\Sigma$ side input)

No. of occupied stations	Area	Points	FP $\Sigma$ CC-Link I/O (installation position) <sup>Note 2</sup>				CC-Link master remote I/O <small>Note 3</small>
			Expansion unit 1	Expansion unit 2	Expansion unit 3	Expansion unit 4	
1	User area	16	X100-X10F	X180-X18F	X260-X26F	X340-X34F	RY00-RY0F
	System area	16	X110-X11F	X190-X19F	X270-X27F	X350-X35F	RY10-RY1F
2	User area	48	X100-X12F	X180-X20F	X260-X28F	X340-X36F	RY00-RY2F
	System area	16	X130-X13F	X210-X21F	X290-X29F	X370-X37F	RY30-RY3F
3	User area	80	X100-X14F	X180-X22F	X260-X30F	X340-X38F	RY00-RY4F
	System area	16	X150-X15F	X230-X23F	X310-X31F	X390-X39F	RY50-RY5F
4	User area	112	X100-X16F	X180-X24F	X260-X32F	X340-X40F	RY00-RY6F
	System area	16	X170-X17F	X250-X25F	X330-X33F	X410-X41F	RY70-RY7F

Note 1: The expansion units closer to the control unit have the lower expansion unit number.  
(Expansion unit 1, 2, 3 and 4)

Note 2: Remote I/O RX and RY are the descriptions for the master station from MITSUBISHI.

### System area allocation (bit)

Master station	FP $\Sigma$ CC-Link <sup>Note</sup>	Signal
RX*0-*A	Y_0-_A	Not available
RX*B	Y_B	Remote station Ready
RX*C-*F	Y_C-_F	Not available
RY*0-*F	X_0-_F	Not available

Note: The value marked with “\_” varies depending on the installation position of the unit.

For details, refer to the allocation tables above.



**Note:** System areas cannot be used in the user program.

## 3.1.2 Shared Memory Allocation

Slot No.

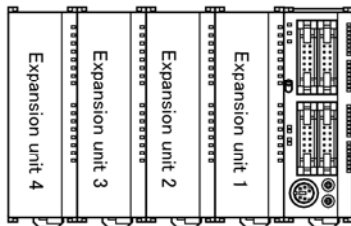

FP $\Sigma$ expansion unit No. <sup>Note)</sup>	1	2	3	4
Shared memory slot No.	0	1	2	3

Note: The expansion units closer to the control unit have the lower expansion unit number. (Expansion unit 1, 2, 3 and 4 in the diagram on the left)

### Error information and status (All the data cannot be updated.)

Shared memory address (word unit: decimal number)	Item			Description
00 to 16	System/reserved area			Not available
17 Setting information (Updated when communication is established)	bit 0 to 3	Station No.	$\times 10^0$	Station No. $\times 10^0$ :0 to 9
	bit 4 to 7	Station No.	$\times 10^1$	Station No. $\times 10^1$ :0 to 6
	bit 8 to B	Baud rate	0 to 4	Baud rate: 0 156kbit/s 1 625kbit/s 2 2.5Mbit/s 3 5Mbit/s 4 10Mbit/s
	bit C~F	Occupied station No.	0 to 3	Occupied station No.: 0 (1 station) to 3 (4 stations)
18 Error information  bit 4, 5, 8, 9 (Other bit: 0)	bit 4	Station No. switch change	0: Normal 1: Error	Station No. switch is changed when power is ON.
	bit 5	Baud rate switch change	0: Normal 1: Error	Baud rate switch is changed when power is ON.
	bit 8	CRC error	0: Normal 1: Error	
	bit 9	Overtime	0: Normal 1: Error	
19	Reserved area			Not available
20 Status information bit 0, 1 (Other bit: 0)	bit 0	Master CPU Operation mode flag	0: STOP 1: RUN	
	bit 1	Master CPU status flag	0: Normal 1: Error	
21 to 31	Setting information			Not available

Remote device (Addresses are indicated in a decimal number.)

FP $\Sigma$ shared memory address			Master station remote register (Hexadecimal)	Number of occupied station			
Instruction	Word address	I/O			2	3	4
F150 Master→FP $\Sigma$	32	Input	RWw0	Available	Available	Available	Available
	33		RWw1	Available	Available	Available	Available
	34		RWw2	Available	Available	Available	Available
	35		RWw3	Available	Available	Available	Available
	36		RWw4	—	Available	Available	Available
	37		RWw5	—	Available	Available	Available
	38		RWw6	—	Available	Available	Available
	39		RWw7	—	Available	Available	Available
	40		RWw8	—	—	Available	Available
	41		RWw9	—	—	Available	Available
	42		RWwA	—	—	Available	Available
	43		RWwB	—	—	Available	Available
	44		RWwC	—	—	—	Available
	45		RWwD	—	—	—	Available
	46		RWwE	—	—	—	Available
	47		RWwF	—	—	—	Available
F151 Master←FP $\Sigma$	48	Output	RWr0	Available	Available	Available	Available
	49		RWr1	Available	Available	Available	Available
	50		RWr2	Available	Available	Available	Available
	51		RWr3	Available	Available	Available	Available
	52		RWr4	—	Available	Available	Available
	53		RWr5	—	Available	Available	Available
	54		RWr6	—	Available	Available	Available
	55		RWr7	—	Available	Available	Available
	56		RWr8	—	—	Available	Available
	57		RWr9	—	—	Available	Available
	58		RWrA	—	—	Available	Available
	59		RWrB	—	—	Available	Available
	60		RWrC	—	—	—	Available
	61		RWrD	—	—	—	Available
	62		RWrE	—	—	—	Available
	63		RWrF	—	—	—	Available

Note: Remote register RWw and RWr are the descriptions for the master station from MITSUBISHI.

# 3.2 FP0 CC-Link Slave Unit

## Communication with FP0 control unit

Only one FP0 CC-Link slave unit can be installed on the extreme right in the expansion unit(s).

In the FP0 CC-Link slave unit;

- CC-Link remote I/O and remote register are allocated to the expansion unit I/O 1<sup>st</sup> word and 2<sup>nd</sup> word (or later), respectively. The number of the word of the remote register varies depending on the expansion unit's installation position.
- Number of remote I/O points: 16 (input points), 16 (output points)
- Remote register: Max. 4 words for read and write each



**Reference:** <3.2.1 Expansion unit I/O allocation>

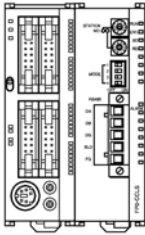

### When 5 words can be used:

Remote I/O : 1 word (input)/1 word (output)

Remote register: 4 words (read)/ 4 words (write)

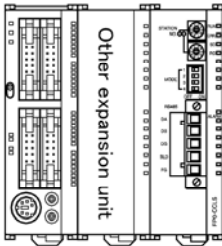

### When 4 words can be used:

Remote I/O : 1 word (input)/1 word (output)

Remote register: 3 words (read)/ 3 words (write)

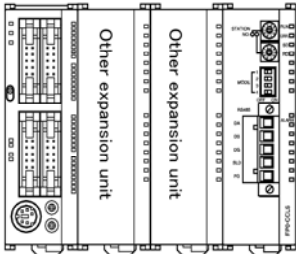

### When 2 words can be used:

Remote I/O : 1 word (input)/1 word (output)

Remote register: 1 word (read)/ 1 word (write)

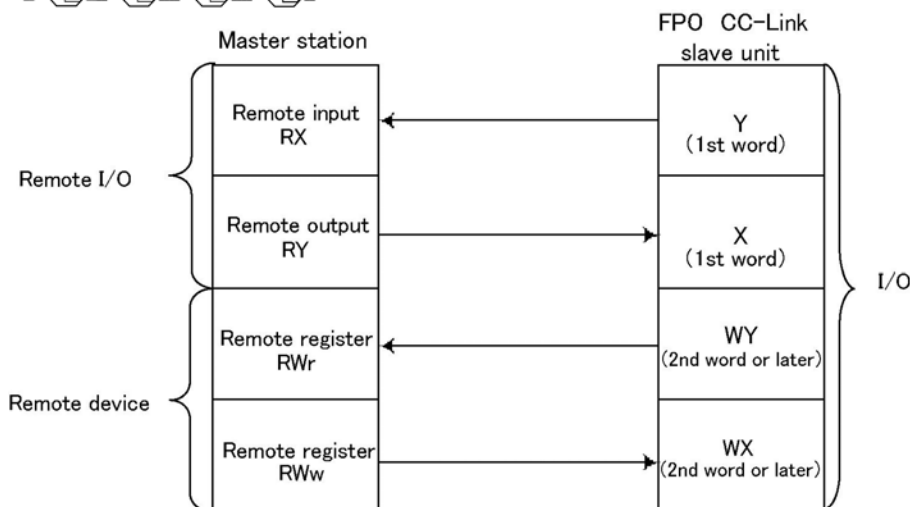

- Note:**
- In the FP0 CC-Link slave unit, shared memory cannot be used.
  - When an expansion unit is newly added after the I/O allocation is set, the I/O allocation is concurrently changed.

## 3.2.1 Expansion Unit I/O Allocation

### Remote input (FP0 side output)

No. of occupied stations	Area	Points	FP0 CC-Link I/O (installation position) <sup>Note1</sup>			CC-Link master remote I/O <sup>Note2</sup>
			Expansion unit 1	Expansion unit 2	Expansion unit 3	
1	I/O	16	Y20-2F	Y40-4F	Y60-6F	RX00-0F
	Register	16	WY3	WY5	WY7	RWr 0
	Register	16	WY4	WY6	-	RWr 1
	Register	16	WY5	WY7	-	RWr 2
	Register	16	WY6	-	-	RWr 3
	System area	16	WY7	-	-	RX10-1F

### Remote output (FP0 side input)

No. of occupied stations	Area	Points	FP0 CC-Link I/O (installation position) <sup>Note1</sup>			CC-Link master remote I/O <sup>Note2</sup>
			Expansion unit 1	Expansion unit 2	Expansion unit 3	
1	I/O	16	X20-2F	X40-4F	X60-6F	RY00-0F
	Register	16	WX3	WX5	WX7	RWw 0
	Register	16	WX4	WX6	-	RWw 1
	Register	16	WX5	WX7	-	RWw 2
	Register	16	WX6	-	-	RWw 3
	System area	16	WX7	-	-	RY10-1F

Note 1: The expansion units closer to the control unit have the lower expansion unit number. (Expansion unit 1, 2 and 3)

Note 2: Remote I/O RX, RY, RWr and RWw are the descriptions for the master station from MITSUBISHI.

### System area allocation (bit)

Master station	FP0 CC-Link	Signal
RX*0-*A	Y70-7A	Not available
RX*B	Y7B	Remote station Ready
RX*C-*F	Y7C-7F	Not available
RY*0-*F	X70-7F	Not available



- Note:**
- 1.Data cannot be written in the system area. (Data can be read from the system area.)
  - 2.System area above can be referred when the FP0 CC-Link slave unit is used as the Expansion unit 1.
  - 3.I/O area which is allocated to the remote register can be used in a word unit.

# 4 Wiring

For details, refer to “CC-Link Cable Wiring Manual” which can be downloaded from the Web site of CC-Link Partner Association free of charge.

For your reference: CC-Link Partner Association (“Precautions before Using CC-link Slave Unit” of this manual.)

English: <https://www.cc-link.org/eng/index.html>

Japanese: <https://www.cc-link.org>

## - CC-Link cables

- Use dedicated CC-Link cables in the CC-Link system.
- If any other cable is used, the performance of the CC-Link system cannot be guaranteed.

Terminal resistor	Cable
110Ω	Dedicated CC-Link cables (for CC-Link Ver. 1.10)
	Dedicated CC-Link cables
130Ω	Dedicated CC-Link high-performance cable

- Make sure to use only one type of cables (CC-Link cables or CC-Link high-performance cables). If both types of cables are used together, normal data transmission cannot be guaranteed.
- For details concerning the specifications and connection for the dedicated CC-Link cables, contact the CC-Link Partner Association.



Reference: CC-Link Partner Association <“Precautions before Using CC-Link Slave Unit” >

## - Wiring with CC-Link cables

- The cables can be connected without regard to the station No..
- Make sure to connect a terminal resistor (provided as an accessory of the unit) between the terminals DA and DB in the units at both ends.
- For details, refer to the CC-Link master station’s manual.

## - Connection

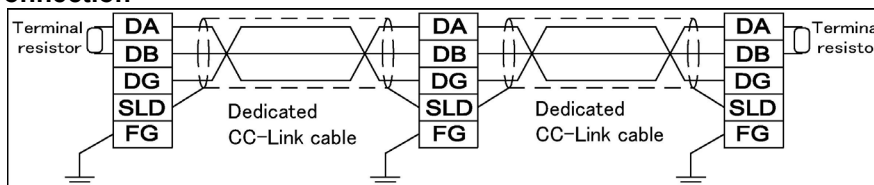

The shielded CC-link cable should go through the terminals SLD and FG in each unit, and both ends should be grounded (less than 100Ω).

The terminals SLD and FG are connected each other inside the unit.

## - When CC-Link slave unit is used as the terminal station:

Secure the cable and terminal resistor to the terminal block using the screws.

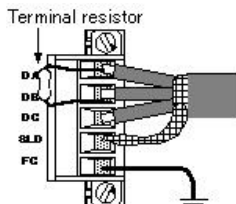

## - When CC-Link slave unit is not used as the terminal station:

Secure the cables to the terminal block using the screws.

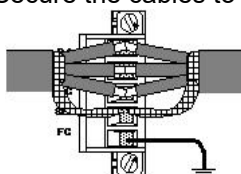



# 5 If an Error Occurs

## 5.1 Troubleshooting

Error	Item	Confirmation
Entire system data link error	Are any cables broken?	Check the cable status visually or by the line test.
	Are terminal resistors properly connected to the stations at the both ends?	Connect terminal resistors (provided for the master station) to the stations at the both ends.
	Has an error occurred in the control unit of the master unit?	Check the error code for the master station and take the proper measure.
	Are parameters set for the master station?	Check the contents of the parameters.
	Has an error occurred in the master station?	Check the followings: <ul style="list-style-type: none"> <li>· Parameter status in the host station</li> <li>· Switch setting status</li> <li>· Installation status</li> <li>· Flashing of "ERR" LED in the master station</li> </ul>
Master side: Remote input (RX) from the CC-Link slave unit cannot be received.  (Check: Output Y on the CC-Link slave unit side)	Does the CC-Link slave unit participate in the data link?	Check the followings: <ul style="list-style-type: none"> <li>· LED indication in the CC-Link slave unit</li> <li>· Communication status in other stations of the master station</li> </ul>
	Is the data read from the correct address of the master station remote input RX?	Check the sequence program in the master station.
	Is the data written in the correct I/O number allocated to the CC-Link slave unit?	Check the sequence program in the FP0/FP $\Sigma$ control unit .
	Is the station specified as reserved one?	Check the contents of the parameters in the master station.
	Does the station No. overlap?	Check the station No.
	Do the connection and setting comply with the specifications for the master station?	Check the specifications for the master station.
Master side: Remote output (RY) from the CC-Link slave unit cannot be turned ON/OFF.  (Check: Input X on the CC-Link slave unit side)	Does the CC-Link slave unit participate in the data link?	Check the followings: <ul style="list-style-type: none"> <li>· LED indication in the CC-Link slave unit</li> <li>· Communication status in other stations of the master station</li> </ul>
	Is the refresh instruction output turned ON in the master station?	Check the sequence program in the master station.
	Is the data written in the correct address of the master station remote output RY?	Check the sequence program in the master station.
	Is the data read from the correct I/O number allocated to the CC-Link slave unit?	Check the sequence program in the FP0/FP $\Sigma$ control unit.
	Is the station specified as reserved one?	Check the contents of the parameters in the master station.
	Does the station No. overlap?	Check the station No.
Master side: Remote register (RWr) data from the CC-Link slave unit cannot be received.  (Check: Output Y on FP0 CC-Link slave unit side, Shared memory address Nos. 48 to 63 on FP $\Sigma$ CC-Link slave unit side)	Does the CC-Link slave unit participate in the data link?	Check the followings: <ul style="list-style-type: none"> <li>· LED indication in the CC-Link slave unit</li> <li>· Communication status in other stations of the master station</li> </ul>
	Is the data read from the correct address of the master station remote register RWr?	Check the sequence program in the master station.
	Is the data written in the correct I/O number (FP0 CC-Link slave unit) and shared memory address (FP $\Sigma$ CC-Link slave unit) allocated to the CC-Link slave unit?	Check the sequence program in the FP0/FP $\Sigma$ control unit.
	Is the station specified as reserved one?	Check the contents of the parameters in the master station.
	Does the station No. overlap?	Check the station No.
	Do the connection and setting comply with the specifications for the master station?	Check the specifications for the master station.
Master side: Remote register (RWw) from the CC-Link slave unit cannot be turned ON/OFF.  (Check: Input X on FP0 CC-Link slave unit side, Shared memory address Nos. 32 to 47 on FP $\Sigma$ CC-Link slave unit side)	Does the CC-Link slave unit participate in the data link?	Check the followings: <ul style="list-style-type: none"> <li>· LED indication in the CC-Link slave unit</li> <li>· Communication status in other stations of the master station</li> </ul>
	Is the data written in the correct address of the master station remote register RWw?	Check the sequence program in the master station.
	Is the data read from the correct I/O number (FP0 CC-Link slave unit) and shared memory address (FP $\Sigma$ CC-Link slave unit) allocated to the CC-Link slave unit?	Check the sequence program in the FP0/FP $\Sigma$ control unit.
	Is the station specified as reserved one?	Check the contents of the parameters in the master station.
	Does the station No. overlap?	Check the station No.
	Do the connection and setting comply with the specifications for the master station?	Check the specifications for the master station.

Note: For details, refer to the CC-Link master station manual.

## 5.2 ERR/ALARM LED

Cause of the ERR/ALARM	LED		FP0/Σ control unit status	CC-Link slave unit status (I/O point, station No., baud rate, occupied number of stations, etc)
	ERR	ALARM		
Station No. setting change	Flashing	OFF	Normal	Operation is not affected. Error flag can be checked in the master station.
Baud rate setting change	Flashing	OFF	Normal	Operation is not affected. Error flag can be checked in the master station.
Station No. setting error	ON	ON	Normal	Operation cannot be executed.
Baud rate setting error	ON	ON	Normal	Operation cannot be executed.
Setting change of occupied number of stations	OFF	ON	I/O verification error	Operation cannot be executed.
Hardware error	—	ON	Extra unit out of control	Operation cannot be executed.

Note 1: "Extra unit out of control" cannot be detected in the FP0 CC-Link slave unit.

When a hardware error occurs in the FP0 CC-Link slave unit, "I/O verification error" is issued.

Note 2: As one occupied station is used for FP0 CC-Link slave unit, FP0 CC-Link slave unit has no LEDs indicating the number of occupied stations.

Therefore, the setting change error of occupied number of stations is not issued.

# 6 Specifications

## 6.1 Specifications

### - General specifications

Item	Description	
Rated voltage	24V DC	
Operating voltage range	21.6 to 26.4V DC	
Rated current consumption	CC-Link unit: 40 mA or less/24V DC	
	Increase amount in the control unit when expansion units are added: 40 mA or less/24V DC	
Allowed momentary power off time	10 ms	
Ambient temperature	0 to 55°C	
Storage temperature	-20 to +70°C	
Ambient humidity	30 to 85 %RH (at 25°C, non condensing)	
Storage humidity	30 to 85 %RH (at 25°C, non condensing)	
Breakdown voltage	Between RS 485 terminals ↔ Power supply terminal Station No.	500V AC for 1 min.
Insulation resistance	Between RS 485 terminals ↔ Power supply terminal Station No.	100 MΩ or more (measured with 500V DC)
Vibration resistance	10 to 55 Hz, 1cycle/1min.: double amplitude of 0.75 mm on 3 axes for 10 min.	
Shock resistance	Shock of 98 m/s <sup>2</sup> or more, 4 times on 3 axes	
Noise immunity	1000 Vp-p with pulse widths 50 ns and 1μs (based on in-house measurement)	
Operating condition	Free from corrosive gases and excessive dust	
Weight	FP Σ CC-Link slave unit	Approx. 90 g
	FP0 CC-Link slave unit	Approx. 80 g

## - CC-Link communication specifications

Item		Description	
Version		CC-Link Ver. 1.10	
Communication method		Broadcast polling method	
Communication speed (Baud rate)		10Mbit/s, 5Mbit/s, 2.5Mbit/s, 625kbit/s, 156kbit/s	
Maximum total cable length <sup>Note1)</sup>		Ver. 1.10 CC-Link cable CC-Link high-performance cable	CC-Link cable
	10Mbit/s	100m	100m
	5Mbit/s	160m	150m
	2.5Mbit/s	400m	200m
	625kbit/s	900m	600m
	156kbit/s	1200m	1200m
Interface		RS485	
Station type		Remote device station	
Number of occupied points	FP $\Sigma$ CC-Link slave unit	1 to 4 stations (switch changeover)	
	FP0 CC-Link slave unit	1 station	

Note 1: Length of the multi-drop connected cables at both ends

The cable length has restrictions in communication speed, CC-Link version, and dedicated cables to be used.

Note 2: For details concerning the CC-Link, refer to the CC-Link Partner Association.



**Reference:** CC-Link Partner Association <Precautions before Using CC-Link Slave Unit>

# 6.2 Dimensions

## - FPΣ CC-Link slave unit (FPG-CCLS) AFIG7943

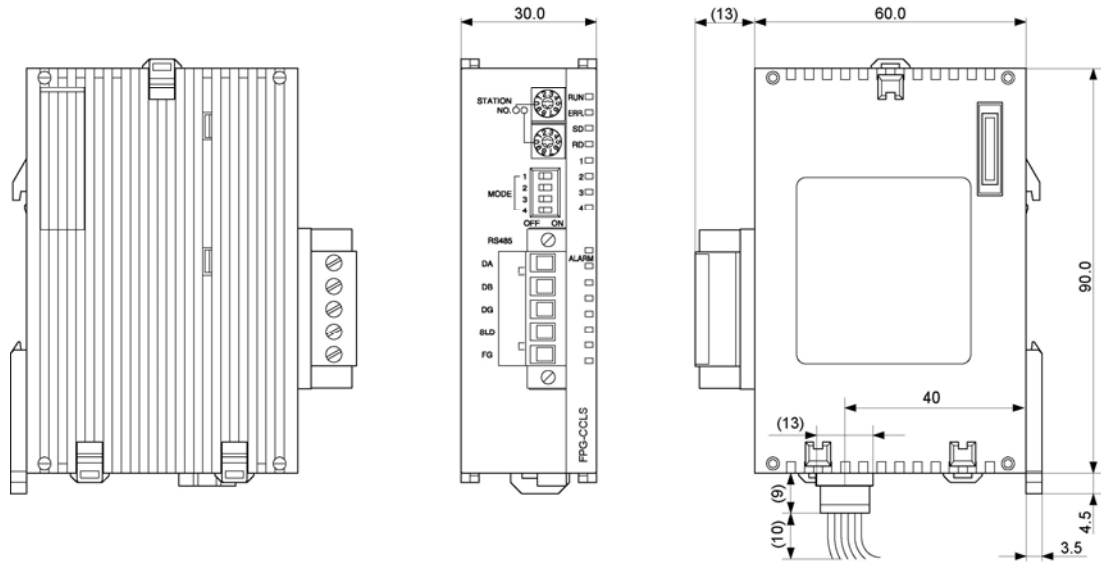

## - FP0 CC-Link slave unit (FP0-CCLS) AFPO7943

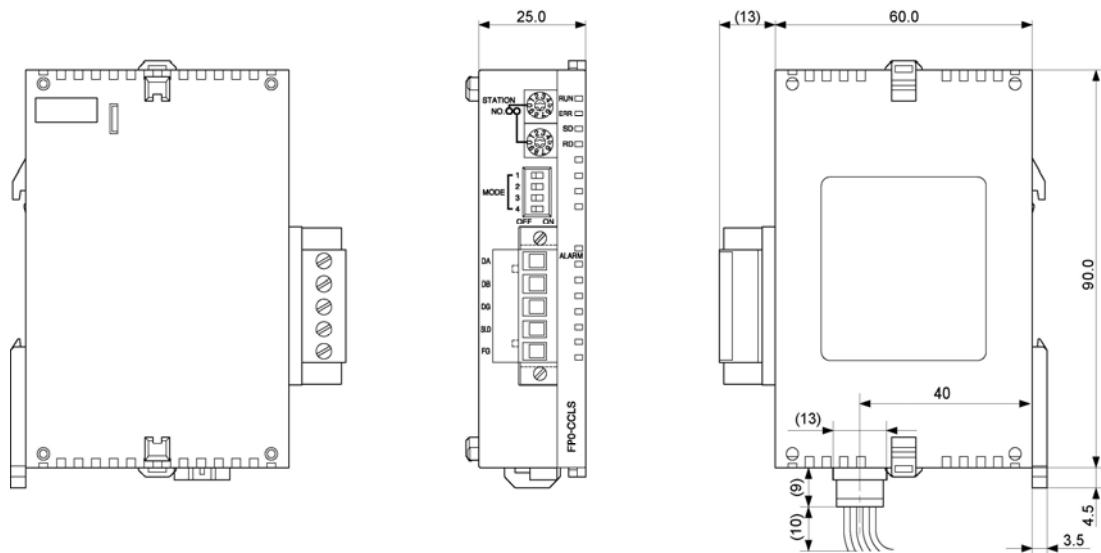



## Record of changes

---

Manual No.	Date	Description of Changes
ARCT1F380E	APR.2003	First edition
ARCT1F380E-1	JUL.2005	2nd edition
ARCT1F380E-2	NOV.2008	3rd edition - Change in Corporate name
ARCT1F380E-3	AUG.2011	4th edition - Change in Corporate name
ARCT1F380E-4	JUL.2013	5th edition - Change in Corporate name
WUME-FP0CCLINK-06	Apr.2024	6th edition - Change in Corporate name







---

## Panasonic Industry Co., Ltd.

1006, Oaza Kadoma, Kadoma-shi, Osaka 571-8506, Japan  
<https://industry.panasonic.com/>

Please visit our website for inquiries and about our sales network.

© Panasonic Industry Co., Ltd. 2003-2024

April, 2024

WUME-FPOCLINK-06