



Programmable Controller

Technical Manual



FP0 RTD Unit

BEFORE BEGINNING

Liability and Copyright for the Hardware

This manual and everything described in it are copyrighted. You may not copy this manual, in whole or part, without written consent of Panasonic Electric Works Europe AG.

Panasonic Electric Works Europe AG pursues a policy of continuous improvement of the design and performance of its products, therefore, we reserve the right to change the manual/product without notice. In no event will Panasonic Electric Works Europe AG be liable for direct, special, incidental, or consequential damage resulting from any defect in the product or its documentation, even if advised of the possibility of such damages.

Please direct support matters and technical questions to your local Panasonic representative.

Panasonic Electric Works Europe AG (PEWEU)

Caroline-Herschel-Straße 100

85521 Ottobrunn, Germany

Tel: +49 89 45 354-1000

LIMITED WARRANTY

If physical defects caused by distribution are found, Panasonic Electric Works Europe AG will replace/repair the product free of charge. Exceptions include:

- When physical defects are due to different usage/treatment of the product other than described in the manual.
- When physical defects are due to defective equipment other than the distributed product.
- When physical defects are due to modifications/repairs by someone other than Panasonic Electric Works Europe AG.
- When physical defects are due to natural disasters.

Important Symbols

One or more of the following symbols may be used in this manual:



◆ NOTE

Contains important additional information.



◆ EXAMPLE

Contains an illustrative example of the previous text section.



◆ PROCEDURE

Indicates that a step-by-step procedure follows.



◆ REFERENCE

Indicates where you can find additional information on the subject at hand.

Table of Contents

1	Unit Outline	1
1.1	Functions	1
1.2	Product Number	1
1.3	Expansion Limit	1
1.4	Part Names and Functions	2
2	Input Range Setting Switch	4
3	Wiring	5
4	Conversion Characteristics	6
4.1	Pt100	6
4.2	Pt1000	8
4.3	Ni1000	10
4.4	Resistor	11
5	I/O Allocation and Sample Programs	13
5.1	I/O Numbers	13
5.2	Programming with FPWIN Pro	16
5.3	Programming with FPWIN GR	17
5.3.1	RTD Types Pt100, Pt1000, Ni1000	17
5.3.2	RTD Type Resistor	18
6	When an Error Occurs	19
6.1	Troubleshooting	19
6.2	Digital Value When Out Of Measuring Range	19
7	Specifications	20
8	Dimensions	23
	Index	25

Precautions Before Use

Accuracy

When extremely sensitive temperature data is required, use the temperature data obtained 15 minutes after turning ON the FP0 RTD unit. (The temperature data obtained in the first 15 minutes is, however, within the total accuracy range.)

A rapid temperature change in the FP0 RTD unit might change the temperature data temporarily.

A draft (air) created e.g. by a cooling fan built into the control panel and blowing on the FP0 RTD unit will lower accuracy. Avoid any kind of draft.

Programming

Between power ON and the first valid conversion data, the digital value will be 8191 or 16383. When programming, be sure not to use the data obtained during this period.

When the RTD is broken, the digital value will change to 8191 or 16383. When programming avoid any risks resulting from a broken RTD. A broken RTD needs to be replaced.

1 Unit Outline

1.1 Functions

RTD input unit for the FP0/FP0R and FPΣ/FP0H CPU.

The temperature data obtained using the RTD (Resistance Temperature Detector) is converted to the digital value to be read into the CPU.

Available RTD types

Pt100 (to IEC751), Pt1000 (to IEC751), Ni1000 (to DIN43760), and Resistor.

Temperature measurement ranges available

RTD Type	°C		°F	
	Resolution 0.1K	Resolution 0.01K	Resolution 0.1°F	Resolution 0.01°F
Pt100	-200.0 ... +500.0	-80.00 ... +80.00	-328.0 ... +800.0	-80.00 ... +80.00
Pt1000	-200.0 ... +300.0	-80.00 ... +80.00	-328.0 ... +572.0	-80.00 ... +80.00
Ni1000	-30.0 ... +150.0	-30.00 ... +80.00	-22.0 ... +302.0	-22.00 ... +80.00

Resistor measurement ranges available

RTD Type	Ω	
	Resolution 1 Ω	Resolution 0.1 Ω
Resistor	20 ... +2200	20.0 ... 1630.0

Conversion to degrees Celsius or degrees Fahrenheit possible

The temperature data measured using the sensor is converted to degrees Celsius or degrees Fahrenheit inside the FP0 RTD unit.

Broken-RTD detector attached

A broken RTD can be detected.

1.2 Product Number

Product name	RTD input points	Product number	Part number
FP0 RTD unit	6 points	FP0RTD6	AFP0430

1.3 Expansion Limit

Number

Up to 3 expansion units can be connected to the CPU.

Position

Always install the FP0 RTD unit the farthest to the right of the CPU.



◆ REFERENCE

For further information, see page 13, I/O Allocation and Sample Programs.

1.4 Part Names and Functions

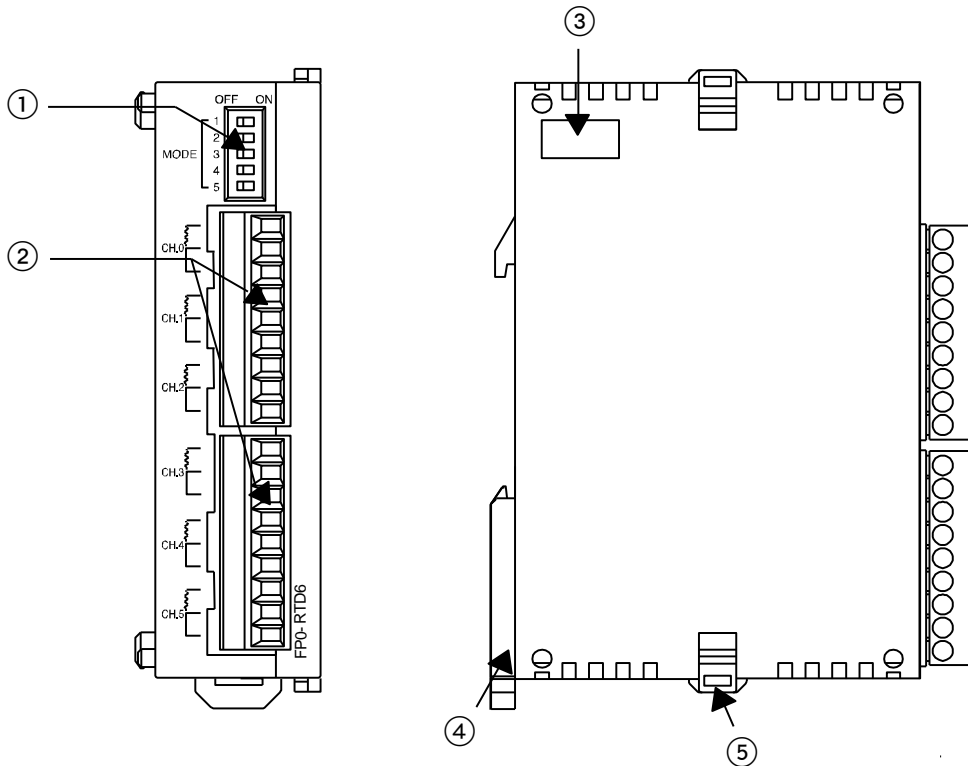

FP0 RTD unit, front and left views

1. Input range setting switch

DIP switches to change between the input ranges (RTD types).



◆ REFERENCE

For further information, see page 4, Input Range Setting Switch

2. RTD input terminal block (9-pin)

Manufactured by Phoenix Contact Co. Model No: MC1.5/9-ST-3.5 (Product No.: 1840434).

Suitable wires

Size	Nominal cross-sectional area
AWG# 28 to 16	0.08 mm ² to 1.25mm ²

3. Expansion connector

Connects the expansion unit to the internal circuit of the control unit.

4. DIN rail attachment lever

The unit can be installed to the DIN rail by one-touch operation. The DIN rail attachment lever is also used for installing the unit to the slim 30 type mounting plate (AFP0803).

5. Expansion hook

Used to secure expansion units.



◆ REFERENCE

Please refer to the CPU hardware manuals for details on connecting and wiring expansion units.

2 Input Range Setting Switch

Input range setting switch

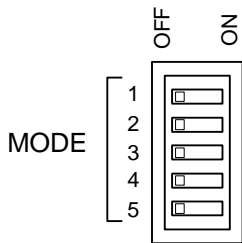

◆ NOTE

The following switch settings are read once when the CPU is turned on. To change the settings, the CPU must be turned off.

Input range setting switch

		OFF	ON	OFF	ON	OFF	ON	OFF	ON
Mode switch	1	<input type="checkbox"/>	<input type="checkbox"/>	<input type="checkbox"/>	<input type="checkbox"/>	<input type="checkbox"/>	<input type="checkbox"/>	<input type="checkbox"/>	<input type="checkbox"/>
	2	<input type="checkbox"/>	<input type="checkbox"/>	<input type="checkbox"/>	<input type="checkbox"/>	<input type="checkbox"/>	<input type="checkbox"/>	<input type="checkbox"/>	<input type="checkbox"/>
CH0, CH1, CH2		Pt100		Pt1000		Ni1000		Resistor	

		OFF	ON	OFF	ON	OFF	ON	OFF	ON
Mode switch	3	<input type="checkbox"/>	<input type="checkbox"/>	<input type="checkbox"/>	<input type="checkbox"/>	<input type="checkbox"/>	<input type="checkbox"/>	<input type="checkbox"/>	<input type="checkbox"/>
	4	<input type="checkbox"/>	<input type="checkbox"/>	<input type="checkbox"/>	<input type="checkbox"/>	<input type="checkbox"/>	<input type="checkbox"/>	<input type="checkbox"/>	<input type="checkbox"/>
CH3, CH4, CH5		Pt100		Pt1000		Ni1000		Resistor	

		OFF	ON	OFF	ON
Mode switch	5	<input type="checkbox"/>	<input type="checkbox"/>	<input type="checkbox"/>	<input type="checkbox"/>
Sampling cycle		0.1s		1s	

3 Wiring

Wiring method

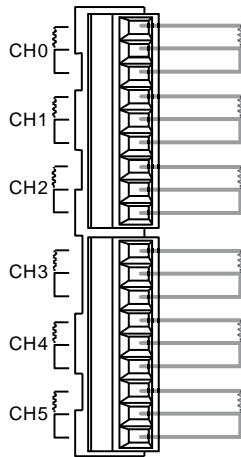

Input line wiring

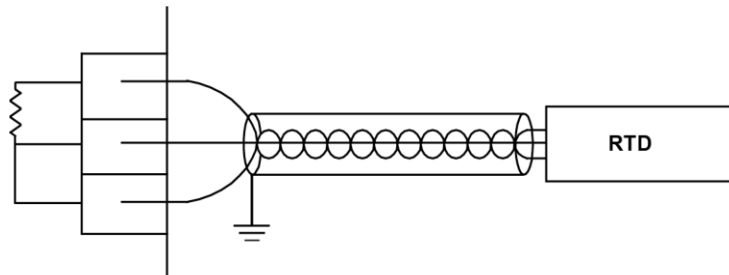

RTD = resistance temperature detector



◆ NOTE

Keep a distance of more than 100mm between the input line and the power line/high-voltage line.

4 Conversion Characteristics



◆ NOTE

The measurement range available for degrees Celsius is larger than for degrees Fahrenheit as the digital value (temperature value displayed) for °F is higher than the one for °C.

4.1 Pt100

Input range:-200.0°C to 500.0°C/-328.0°F to 800.0°F, resolution: 0.1K/0.1°F

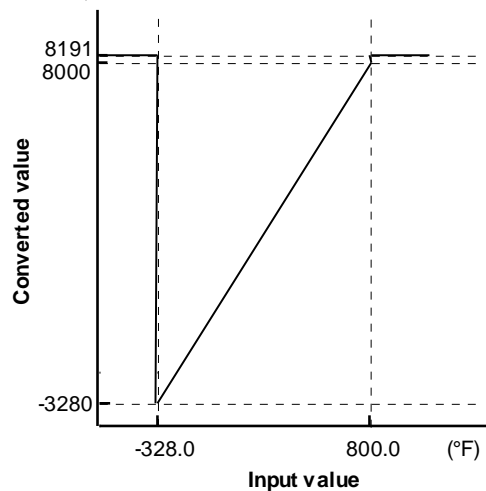
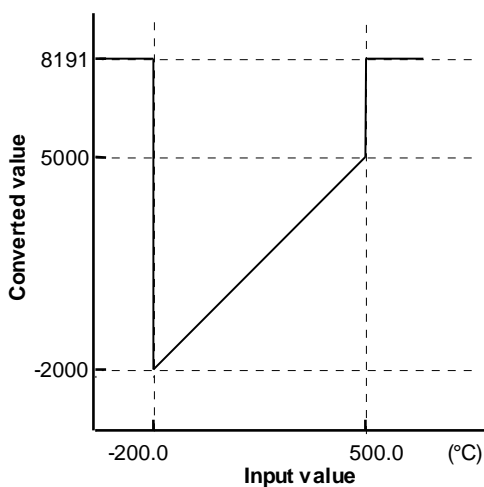

A/D conversion table

Analog input value (°C)	Digital output value
-200.0	-2000
+500.0	+5000

Analog input value (°F)	Digital output value
-328.0	-3280
+800.0	+8000

Processing if the input value range is exceeded

Analog input value (°C)	Digital output value
-200.1 or less	8191
+500.1 or more	
RTD broken	

Analog input value (°F)	Digital output value
-328.1 or less	8191
+800.1 or more	
RTD broken	

Input range:-80.00°C to 80.00°C/-80.00°F to 80.00°F, resolution: 0.01K/0.01°F

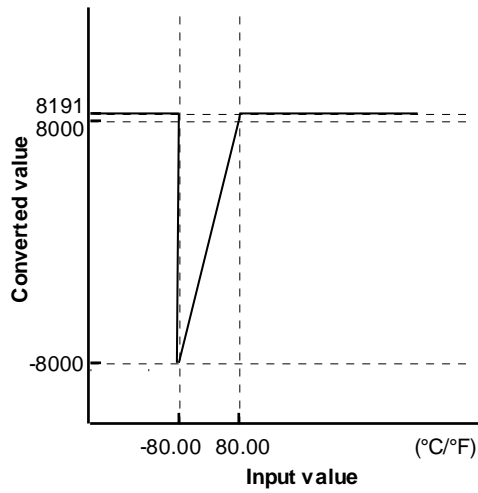

A/D conversion table

Analog input value (°C)	Digital output value
-80.00	-8000
+80.00	+8000

Analog input value (°F)	Digital output value
-80.00	-8000
+80.00	+8000

Processing if the input value range is exceeded

Analog input value (°C)	Digital output value
-80.01 or less	8191
+80.01 or more	
RTD broken	

Analog input value (°F)	Digital output value
-80.01 or less	8191
+80.01 or more	
RTD broken	

4.2 Pt1000

Input range: -200.0°C to 300.0°C/-328.0°F to 572.0°F, resolution: 0.1K/0.1°F

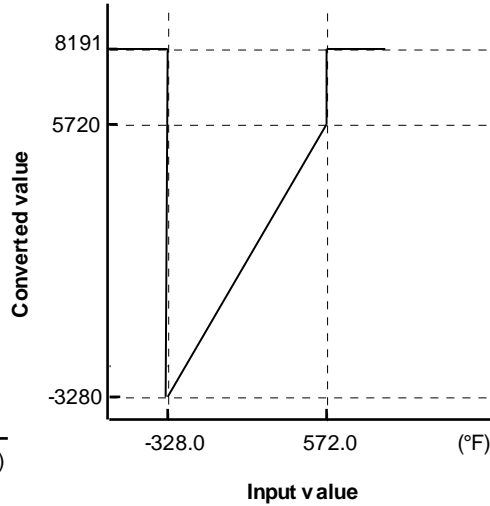
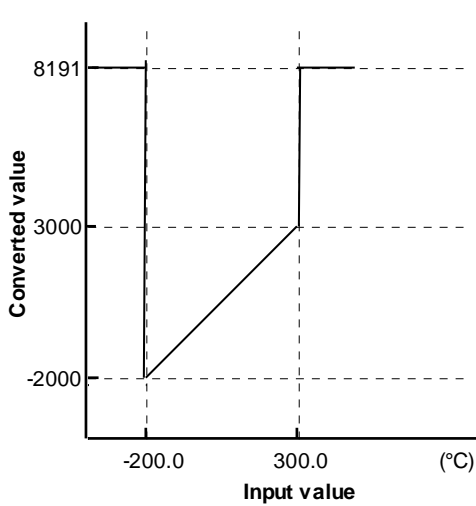

A/D conversion table

Analog input value (°C)	Digital output value
-200.0	-2000
+300.0	+3000

Analog input value (°F)	Digital output value
-328.0	-3280
+572.0	+5720

Processing if the input value range is exceeded

Analog input value (°C)	Digital output value
-200.1 or less	8191
+300.1 or more	
RTD broken	

Analog input value (°F)	Digital output value
-328.1 or less	8191
+572.1 or more	
RTD broken	

Input range: -80.00°C to 80.00°C/-80.00°F to 80.00°F, resolution: 0.01K/0.01°F

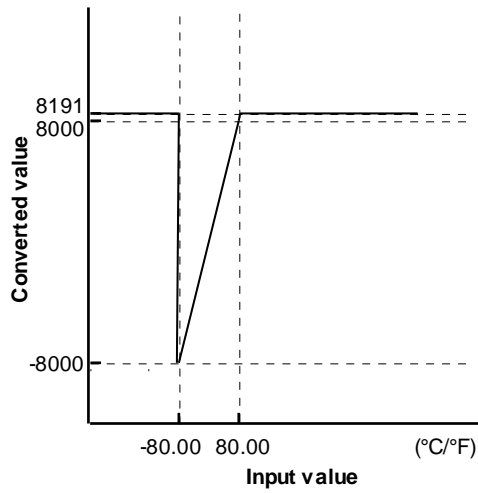

A/D conversion table

Analog input value (°C)	Digital output value
-80.00	-8000
+80.00	+8000

Analog input value (°F)	Digital output value
-80.00	-8000
+80.00	+8000

Processing if the input value range is exceeded

Analog input value (°C)	Digital output value
-80.01 or less	8191
+80.01 or more	
RTD broken	

Analog input value (°F)	Digital output value
-80.01 or less	8191
+80.01 or more	
RTD broken	

4.3 Ni1000

Input range: -30.0°C to 150.0°C/-22.0°F to 302.0°F), resolution: 0.1K/0.1°F

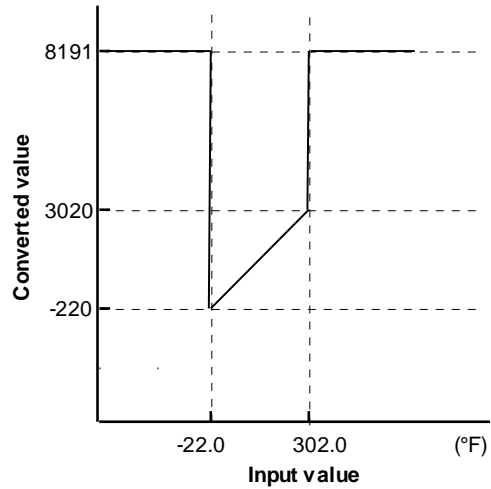
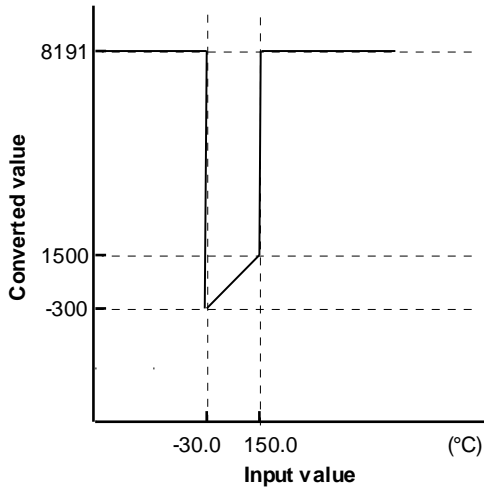

A/D conversion table

Analog input value (°C)	Digital output value
-30.0	-300
+150.0	+1500

Analog input value (°F)	Digital output value
-22.0	-220
+302.0	+3020

Processing if the input value range is exceeded

Analog input value (°C)	Digital output value
-30.1 or less	8191
+150.1 or more	
RTD broken	

Analog input value (°F)	Digital output value
-22.1 or less	8191
+302.1 or more	
RTD broken	

Input range: -30.00°C to 80.00°C/-22.00°F to 80.00°F, resolution: 0.01K/0.01°F

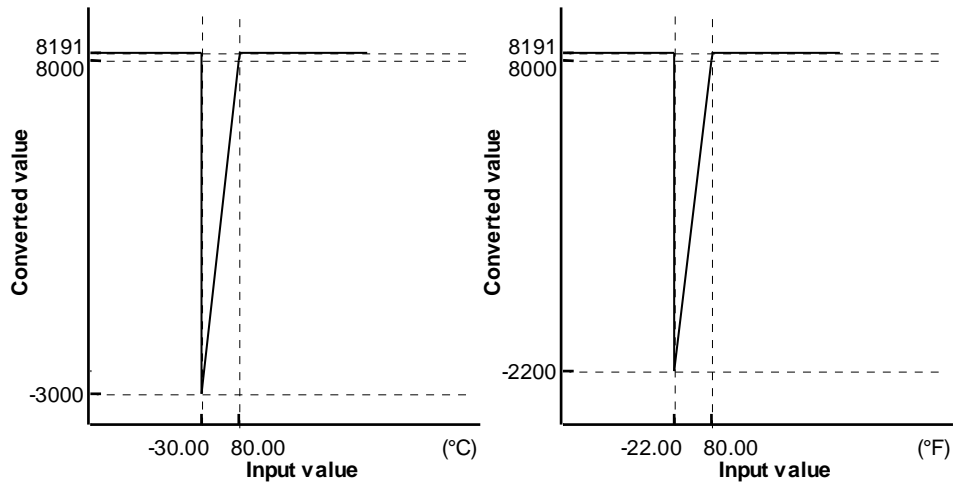

A/D table

Analog input value (°C)	Digital output value
-30.00	-3000
+80.00	+8000

Analog input value (°F)	Digital output value
-22.00	-2200
+80.00	+8000

Processing if the input value range is exceeded

Analog input value (°C)	Digital output value
-30.01 or less	8191
+80.01 or more	
RTD broken	

Analog input value (°F)	Digital output value
-22.01 or less	8191
+80.01 or more	
RTD broken	

4.4 Resistor

Input range: 20Ω to 2200Ω, resolution: 1Ω

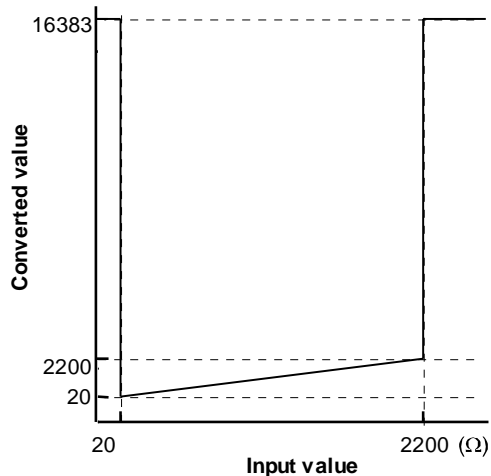

A/D conversion table

Analog input value (Ω)	Digital output value
+20	+20
+2200	+2200

Processing if the input value range is exceeded

Analog input value (Ω)	Digital output value
+19 or less	16383
+2201 or more	
Resistor broken	

Input range: 20.0 Ω to 163.0 Ω , resolution: 0.1 Ω

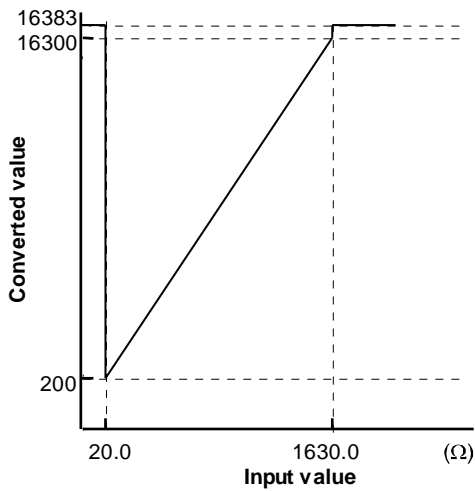

A/D conversion table

Analog input value (Ω)	Digital output value
+20.0	+200
+1630.0	+16300

Processing if the input value range is exceeded

Analog input value (Ω)	Digital output value
+19.9 or less	16383
+1630.1 or more	
Resistor broken	

5 I/O Allocation and Sample Programs

5.1 I/O Numbers

Up to three expansion units including the FP0 RTD unit can be connected to the CPU (2 words [2x16 bits] are assigned to each WX and WY).

I/O Numbers

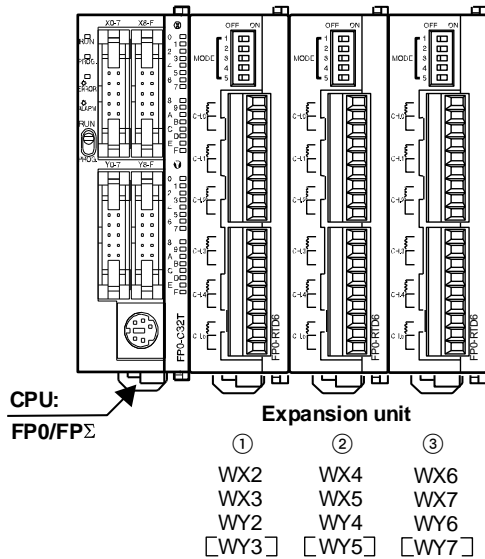

WY3, WY5, and WY7 are allocated but not used.



NOTE

Always install the FP0 RTD unit the farthest to the right of the control unit.

With the setup illustrated above, the I/O data is allocated as in the table below.

		Expansion unit no.1	Expansion unit no.2	Expansion unit no.3
Input channel	CH0, 2, 4	WX2	WX4	WX6
	CH1, 3, 5	WX3	WX5	WX7
Output		WY2	WY4	WY6

Example for address assignment

The figure below shows the conversion data for the different channels. The I/O addresses vary depending on the position of the RTD unit. In this example, the RTD unit is installed directly next to the control unit as expansion unit no. 1, and WX2 and WX3 are allocated.

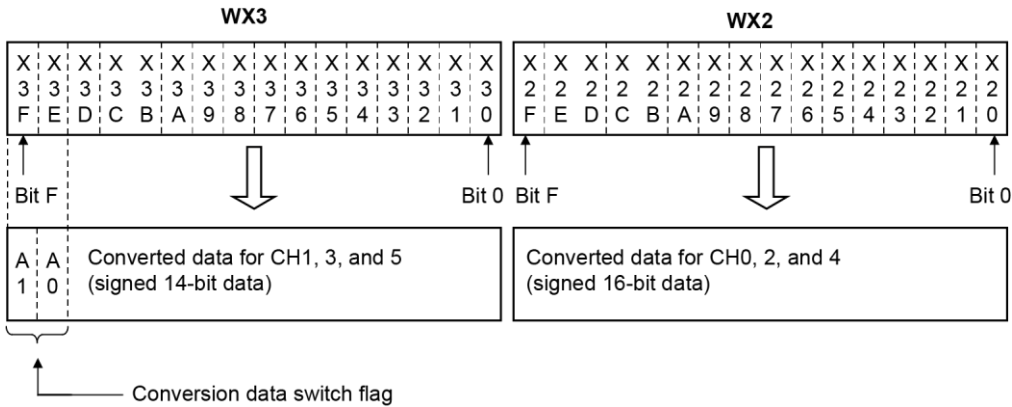

A1	A0	WX3	WX2
0	0	CH1 data	CH0 data
0	1	CH3 data	CH2 data
1	0	CH5 data	CH4 data

Conversion data switch flags

The analog unit has a 12-bit resolution. Before the data from the FP0 RTD unit is transferred to the control unit, the data for WX3 is converted to 16-bit data as bits E and F are used as conversion data switch flags. Data for WX2 need not be converted. (WX2 and WX3 apply if the FP0 RTD unit is installed as expansion no. 1).

When the conversion data is negative, the data from WX2 and WX3 is represented as two's complement: bits C to F of WX2 and bits C to D of WX3 will be "1".

After saving the channel information, the conversion data switch flags need to be masked. They must be converted to "00" when the data is positive and to "11" when it is negative.

Data for CH3	WX3	→	Data after masking
1	0100000000000001	→	0000000000000001
-1	0111111111111111	→	1111111111111111

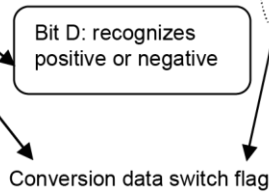

As resistor data is only positive, bit 0 to bit F for WX2 and bit 0 to bit D for WX3 can be used to represent the resistance values.

Bit E and bit F for WX3 are used as conversion data switch flags. After saving the channel information, the conversion data switch flags need to be masked. They must be converted to "00" as the data is positive.

Data for CH3	WX3	→	Data after masking
1	0100000000000001	→	0000000000000001

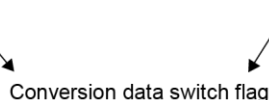



NOTE

A simple way of processing positive and negative data is shown in the programming examples on the following pages.

Assignment of outputs Y20...Y27

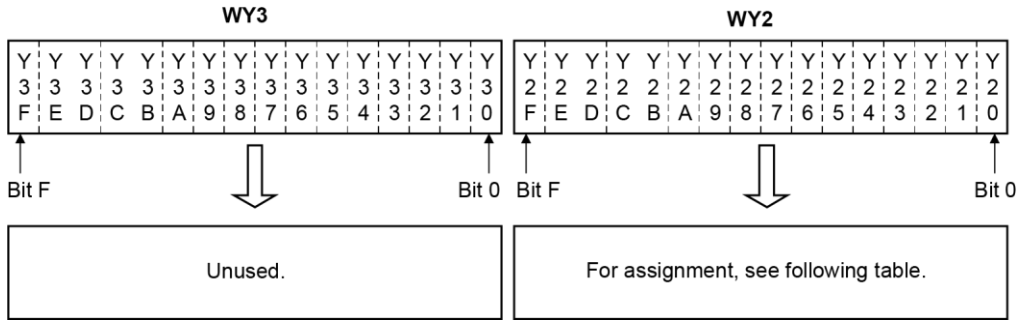

	Off	On
Y20	°C	°F
Y21	CH0: 0.1°C/°F	CH0: 0.01°C/°F
Y22	CH1: 0.1°C/°F	CH1: 0.01°C/°F
Y23	CH2: 0.1°C/°F	CH2: 0.01°C/°F
Y24	CH3: 0.1°C/°F	CH3: 0.01°C/°F
Y25	CH4: 0.1°C/°F	CH4: 0.01°C/°F
Y26	CH5: 0.1°C/°F	CH5: 0.01°C/°F
Y27	Always off	Always off
Y28...Y2F	Unused	

5.2 Programming with FPWIN Pro

Control FPWIN Pro provides convenient function blocks (“Unit_AnalogInput_FP0_RTD_INT” and “Unit_AnalogInput_FP0_RTD_REAL”) to read data from the input channels. They can be used for all RTD types (Pt100, Pt1000, Ni1000, and Resistor). You can find the function blocks in the FP tool library.



◆ REFERENCE

For details on how to use the function blocks, refer to the description of each function block in the online help of Control FPWIN Pro.

5.3 Programming with FPWIN GR

5.3.1 RTD Types Pt100, Pt1000, Ni1000

Ladder program to read data from input channels

This program shows you how to store temperature data for CH0 to CH5 of the FP0 RTD unit installed as expansion unit no.1 in data registers DT0 to DT5.



◆ EXAMPLE



◆ REFERENCE

For further information, see page 13, I/O Allocation and Sample Programs.

5.3.2 RTD Type Resistor

Ladder program to read data from input channels

This program shows you how to store temperature data for CH0 to CH5 of the FP0 RTD unit installed as expansion unit no.1 in data registers DT0 to DT5.



◆ EXAMPLE

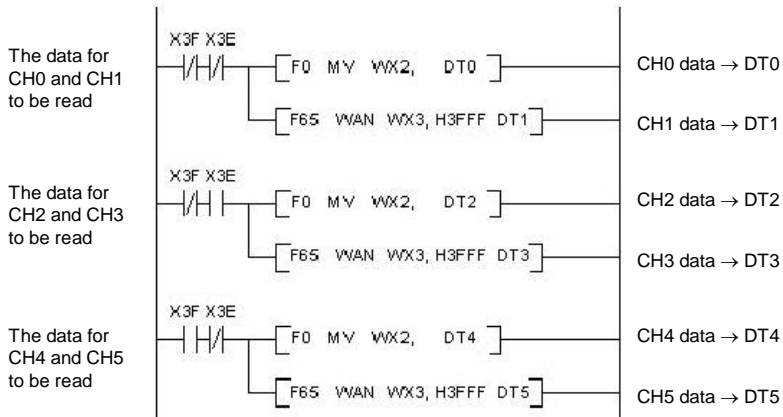

◆ REFERENCE

For further information, see page 13, I/O Allocation and Sample Programs.

6 When an Error Occurs

6.1 Troubleshooting



PROCEDURE

1. Check whether the input signal lines are connected properly.

When the RTD is not connected properly or broken, K8191 is displayed for RTD types Pt100, Pt1000, and Ni1000. K16383 is displayed for the RTD type Resistor.

2. Check whether the input range setting switch is set properly.

It specifies the allowed temperature range and the RTD type.

3. Use the programs described above.



REFERENCE

For further information, see page 4, Input Range Setting Switch and page 13, I/O Allocation and Sample Programs.

6.2 Digital Value When Out Of Measuring Range

When the input of the FP0 RTD unit is out of the measuring range, the following digital values are displayed:

	Pt100 [°C/°F]		Pt1000 [°C/°F]		Ni1000 [°C/°F]		Resistor [Ω]	
Resolution [K/°F]	0.1	0.01	0.1	0.01	0.1	0.01	1	0.1
Temperature measured > upper-limit	8191						16383	
Temperature measured < lower-limit								
RTD connected improperly or broken								

7 Specifications

General specifications

Parameter	Specifications
Increase of current consumption in control unit	25mA or less (24V DC)
Operating temperature	0°C to +55°C
Storage temperature	-20°C to +70°C
Operating humidity	30% RH to 85% RH (no condensing)
Storage humidity	30% RH to 85% RH (no condensing)
Vibration resistance	10Hz to 55Hz, 1 cycle/min: double amplitude of 0.75mm for 10 min. on 3 axes (toward X, Y and Z directions)
Shock resistance	98m/s ² for 4 times on 3 axes (toward X, Y and Z directions)
Noise immunity	1000V [P-P] with pulse widths 50ns and 1μs (using noise simulator)
Operating conditions	Free from corrosive gases and excessive dust.
Weight	Approx. 75g

Input specifications

Parameter	Specification				
Input channels	Up to 6 channels per unit				
Input range	Pt100	Resolution 0.1	-200.0°C to 500.0°C -328.0°F to 800.0°F (see note 1)		
		Resolution 0.01	-80.00°C to 80.00°C -80.00°F to 80.00°F (see note 1)		
	Pt1000	Resolution 0.1	-200.0°C to 300.0°C -328.0°F to 572.0°F (see note 1)		
		Resolution 0.01	-80.00°C to 80.00°C -80.00°F to 80.00°F (see note 1)		
	Ni1000	Resolution 0.1	-30.0°C to 150.0°C -22.0°F to 302.0°F (see note 1)		
		Resolution 0.01	-30.00°C to 80.00°C -22.00°F to 80.00°F (see note 1)		
	Resistor	Resolution 1	20Ω to 2200Ω		
		Resolution 0.1	20.0Ω to 1630.0Ω		
	Digital output	Pt100	Resolution 0.1	-200.0 to 500.0°C: -328.0 to 800.0°F:	-2000 to 5000 -3280 to 8000
			Resolution 0.01	-80.00 to 80.00°C: -80.00 to 80.00°F:	-8000 to 8000 -8000 to 8000
Pt1000		Resolution 0.1	-200.0 to 300.0°C: -328.0 to 572.0°F:	-2000 to 3000 -3280 to 5720	
		Resolution 0.01	-80.00 to 80.00°C: -80.00 to 80.00°F:	-8000 to 8000 -8000 to 8000	
Ni1000		Resolution 0.1	-30.0 to 150.0°C: -22.0 to 302.0°F:	-300 to 1500 -220 to 3020	
		Resolution 0.01	-30.00 to 80.00°C: -22.00 to 80.00°F:	-3000 to 8000 -2200 to 8000	
Resistor		Resolution 1	20 to 2200Ω:	20 to 2200	
		Resolution 0.1	20.0Ω to 1630.0Ω:	200 to 16300	
When out of range or RTD is broken: 8191 or 16383 (see note 2) Until temperature can be measured at initial startup: see note 3					
Resolution		0.1K/°F, 0.01K/°F			
Sampling cycle	0.1 or 1s for all channels (see note 4)				
Accuracy	Pt100	Cycle 1s	Ambient temp.: 25°C	0.3K (-10°C to +30°C) 0.2%/1.4K (-200°C to +500°C)	
			Whole temp. range	0.35%/2.5K	
		Cycle 0.1s	Whole temp. range	0.5%/3.5K	
	Pt1000	Cycle 1s	Ambient temp.: 25°C	0.3K (-10°C to +30°C) 0.2%/1.0K (-200°C to +300°C)	
			Whole temp. range	0.35%/1.7K	
		Cycle 0.1s	Whole temp. range	0.5%/2.5K	
	Ni1000	Cycle 1s	Whole temp. range	1K	
		Cycle 0.1s	Whole temp. range	2K	

Parameter	Specification			
	Resistor	Cycle 1s	Whole temp. range	1Ω (20 to 2200Ω)
		Cycle 0.1s	Whole temp. range	2Ω (20 to 2200Ω)
Insulation method	none			
Input/output points	Input	32 points:	16 points for WX2, 4, 6	Analog input CH0, 2, 4 (WX2) (see notes 5 and 6)
			16 points for WX3, 5, 7	Analog input CH1, 3, 5 (WX3) (see notes 5 and 6)
	Output	8 + 24 points (reserved)		



◆ NOTE

1. The measurement range available for degrees Celsius is larger than for degrees Fahrenheit as the digital value (temperature value displayed) for °F is higher than the one for °C.
2. When the RTD is broken, the digital value will change to 8191 or 16383. Use a program to avoid risks resulting from a broken RTD. A broken RTD needs to be replaced.
3. Until conversion data is ready after the initial startup, the digital value shows 8191 or 16383. These are not temperature data. Program in such a way that these values are not interpreted as temperature data.
4. These are the settings of the input channel selection switch.
5. The control unit reads data from 2 channels in one scan. Read data by using the programs described above.
6. This address applies when the FP0 RTD unit is installed as expansion unit no. 1.

Block diagram

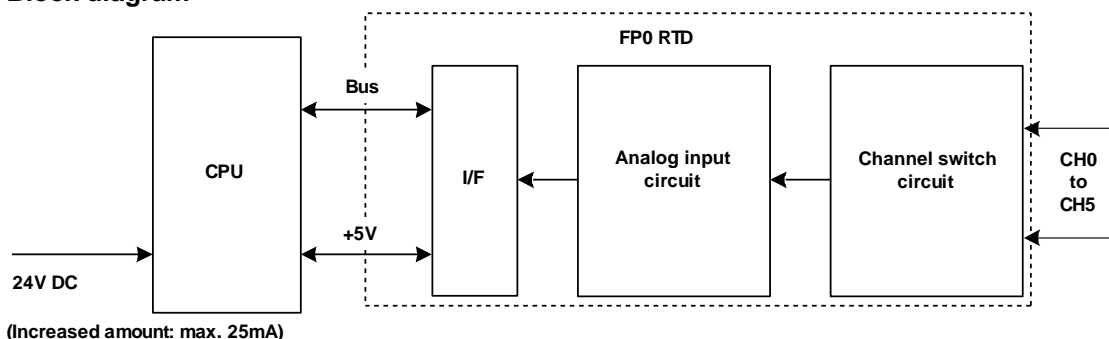

8 Dimensions

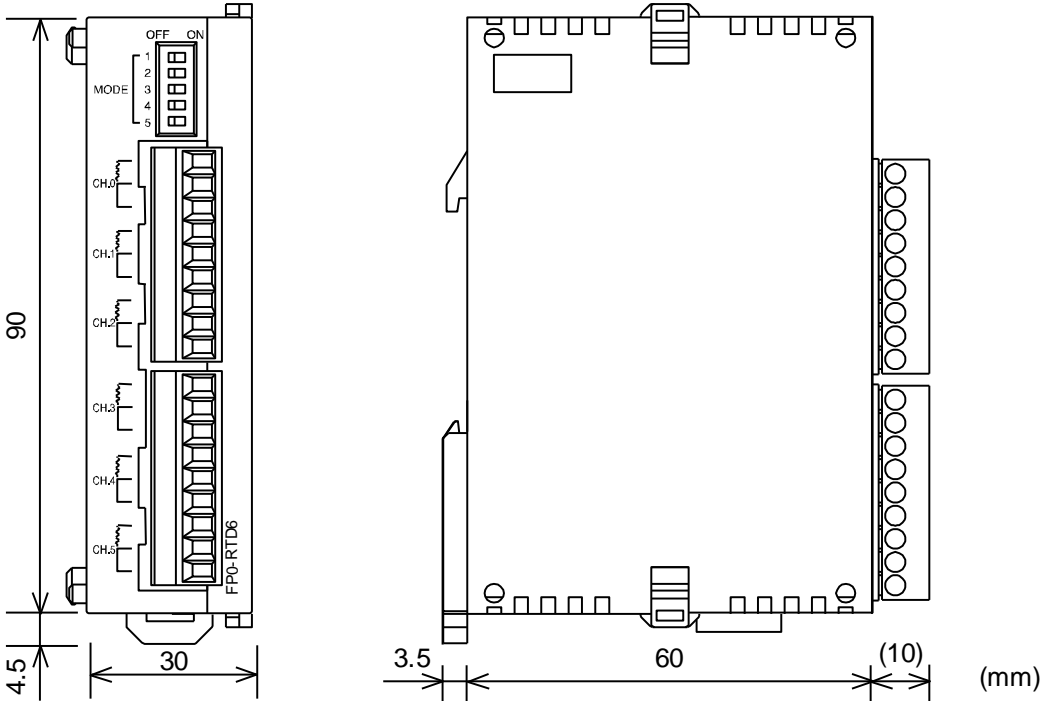

Index

1

16383
digital output value..... 12

8

8191
digital output value.....6, 7, 8, 9, 10, 11

A

A/D conversion values See Conversion characteristics
Accuracy iv, 21
Addresses 13

B

Block diagram 22
Broken-RTD detector 1, 22

C

Celsius 1
Conversion characteristics
 Ni1000 10
 Pt100 6
 Pt1000 8
 Resistor..... 11
Conversion data switch flag..... 13
Current consumption increase..... 20

D

Digital output 21
Dimensions 23
DIN rail attachment lever 3

E

Expansion 1, 13
Expansion connector 3
Expansion hook 3

F

Fahrenheit..... 1
FPWIN GR
 Programming 17
FPWIN Pro

 Programming 16
Function block..... 16

I

I/O allocation 13
I/O numbers 13
Input channels 13, 21
Input range..... 21
Input range setting switch 2, 4
Input/output points 22
Insulation method 22

M

Measurement ranges..... 1
Mode switch..... 4

N

Ni1000
 Conversion characteristics 10
 Measurement range 1
Noise immunity 20

O

Operating conditions..... 20
Operating humidity..... 20
Operating temperature..... 20
Output assignments..... 15

P

Product number 1
Programming
 FPWIN GR..... 17
 FPWIN Pro..... 16
Pt100
 Conversion characteristics 6
 Measurement range 1
Pt1000
 Conversion characteristics 8
 Measurement range 1

R

Read_RTD6..... 16
Resistor
 Conversion characteristics 11
 Measurement range 1
Resolution 21

RTD types 1

S

Sampling cycle.....21

Shock resistance20

Specifications.....20

Storage humidity20

Storage temperature20

T

Troubleshooting 19

V

Vibration resistance20

W

Weight.....20

Wires2

Wiring.....5

Record of Changes

Manual No.	Date	Description of Changes
ACGM0159V10END	Sept. 2004	First Edition
ACGM0159V11END	Sept. 2006	Update company name and Web site.
ACGM0159V12END	Dec. 2006	Minor restructuring in preparation for localization.
ACGM0159V13END	Dec. 2008	Minor errors corrected: vibration resistance parameter 0.75mm; under conversion data switch flag, behavior of WX2 and WX3.
ACGM0159V14END	May 2021	Update company name and Web site.