

Contact-Type Digital Displacement Sensor / Controller HG-SC□

MJE-HGSC No.0066-46V

Thank you very much for purchasing Panasonic products. Read this Instruction Manual carefully and thoroughly for the correct and optimum use of this product. Kindly keep this manual in a convenient place for quick reference.

⚠ WARNING

- Never use this product as a device for personnel protection.
- When using devices for personnel protection, use products that meet the laws and standards for personnel protection that apply in each region or country, such as OSHA, ANSI and IEC.

This document provides a brief summary of mounting, wiring, and other related information. For detailed information, refer to the "HG-S Series User's Manual" (our web site: <https://panasonic.net/id/pidsx/global>).

1 STANDARDS AND REGULATIONS

- This product conforms to the standards and regulations below.

<European Directives>

EMC Directive



• Contact for CE

Panasonic Marketing Europe GmbH Panasonic Testing Center
Winsbergring 15, 22525 Hamburg, Germany

2 CONTENTS OF PACKAGE

- Controller 1 pc.
- Instruction Manual (English / Japanese, Chinese / Korean) 1 pc. each
- General Information for Safety, Compliance, and Instructions (23 languages) 1 pc.

3 DESCRIPTION OF PARTS

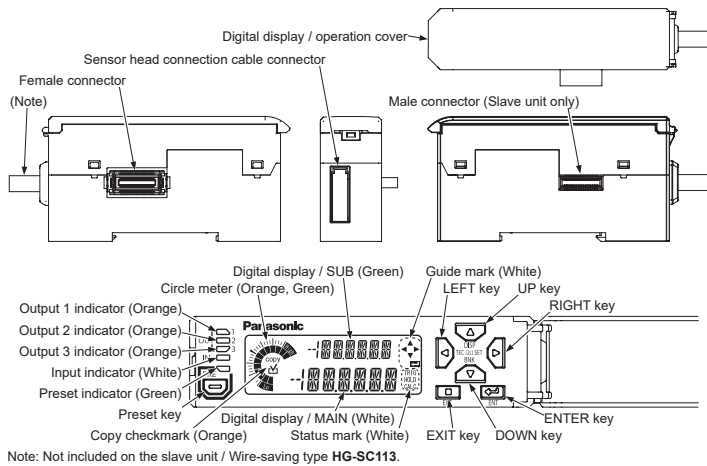

4 MOUNTING

How to mount

1. Fit the rear part of the mounting section of the controller on a DIN rail.
2. Press down the rear part of the mounting section of the unit on the DIN rail and fit the front part of the mounting section to the DIN rail.

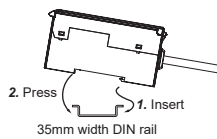

How to remove

1. Push the controller forward.
2. Lift up the front part of the controller to remove it.

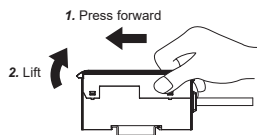

Connecting the sensor head connection cable

How to mount

1. Insert the sensor head connection cable into the connector for the sensor head connection cable on the controller.

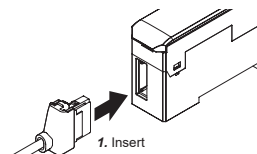

Note: Insert the connector firmly. Risk of sensor head or controller damage if not completely connected.

How to remove

1. Grasp the controller, and while pressing on the release lever on the connector of the sensor head connection cable, pull the cable toward you to disconnect.

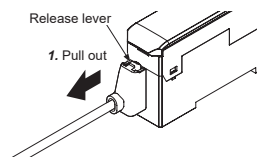

Note: Do not pull by holding the cable without pressing the release lever, as this can cause cable break or connector break.

5 CONNECTING SLAVE UNITS

- Always shut off the power before connecting a slave unit to or disconnecting a slave unit from the master unit. Risk of controller damage if you attempt connection with the power ON.
- When the HG-S controller and HG-T controller are used in combination, connect the slave units of the same series to the side closer to the master unit, and connect the slave units of the different series to the far side.
- When the HG-S controller and HG-T controller are used in combination, some functions such as computation function and copy function are restricted. For detailed information, refer to the "HG-S Series User's Manual" (our web site: <https://panasonic.net/id/pidsx/global>).
- Insert the male connector firmly into the female connector. Risk of controller damage if not completely connected.
- To connect units, the units must be mounted on a DIN rail. Attach end plates MS-DIN-E (optional) so as to enclose the connected units at the ends.
- Up to 15 slave units can be connected per master unit. (When communication unit consolidated: up to 14 slave units)
- When connecting slave units to a master unit, connect only NPN output types, or only PNP output types. Dissimilar output types cannot be connected together.

To mount or remove a controller, refer to "4 MOUNTING".

How to connect

1. Mount one master unit on the DIN rail.
2. Remove the connector cover.
3. Mount each slave unit one at a time on the DIN rail. Remove all connector covers except for the cover on the last end slave unit.
4. Slide each slave unit and connect the female and male connectors.
5. Attach end plates MS-DIN-E (optional) with the flat side facing in so as to enclose the connected units at the ends.
6. Tighten the screws to fasten the end plates.

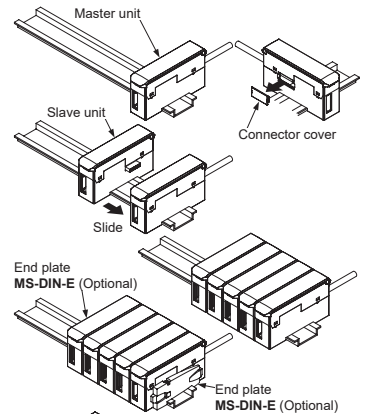

How to remove

1. Loosen the screws on the end plate.
2. Remove the end plate.
3. Slide and remove the controllers, one at a time.

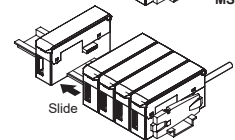

6 I/O CIRCUIT DIAGRAMS

Input circuit diagrams

• NPN output type

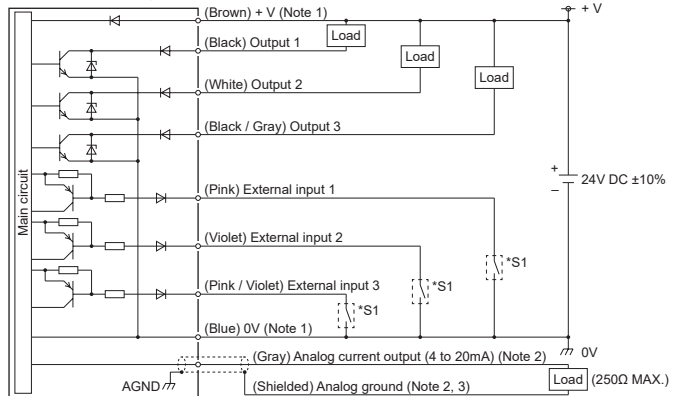

• PNP output type

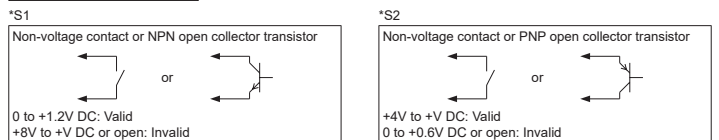
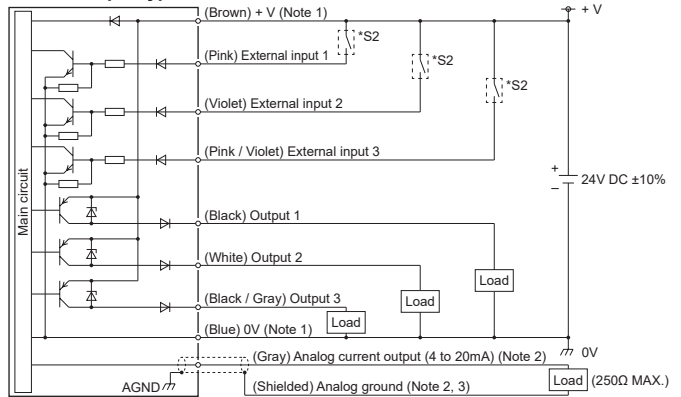

- Notes: 1) The HG-SC111□ and HG-SC112□ cables do not have +V or 0V. Power is supplied from the connector of the master unit.
2) The HG-SC112□ cables do not have analog current output or analog ground.
3) Use shielded wire for the analog output.

7 BASIC OPERATION

For details on the procedures for operating the product, refer to the "HG-S Series User's Manual" (our web site: <https://panasonic.net/id/pidsx/global>).

- The modes and shortcut functions that can be used from the home screen after the power is turned ON are as follows.

1. Display switching mode (long press UP key for 2 seconds)

You can change the display of the digital display / SUB (green) as needed for the task.

Normal measured value	Calculated value	Label	LOW set value	HIGH set value	Sensor head measured value
NDRAW 05000	CALE 05000	LABEL 05000	LOSET 05000	HISET 05000	HEADW 05000

2. Teaching mode (long press LEFT key for 2 seconds)

Automatically set HIGH and LOW set values and output HI / GO / LO decision values.

<Example> 1-point teaching

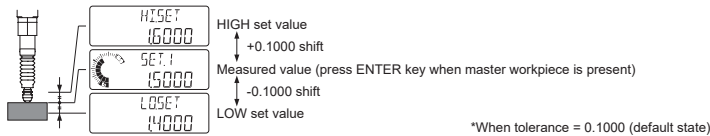

3. HIGH set value fine adjustment function (short-press UP key)

You can fine adjust the HIGH set value as needed.



4. LOW set value fine adjustment function (short-press DOWN key)

You can fine adjust the LOW set value as needed.



5. Bank mode (long press DOWN key for 2 seconds)

You can write / read the HIGH set value or LOW set value to / from a specified bank (1 to 3).

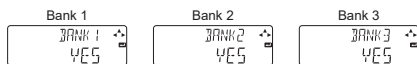

6. Setting mode (long press RIGHT key for 2 seconds)

You can change basic settings or configure advanced function settings.

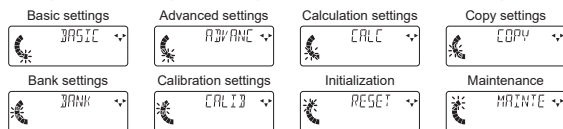

7. Preset (short-press PRESET key)

You can perform zero-point adjustment, and shift to any preset value.

You can cancel preset by long-pressing the preset key for 2 seconds.



8. Key lock (long press ENTER key + EXIT key for 3 seconds)

You can prevent accidental key operation during measurement.

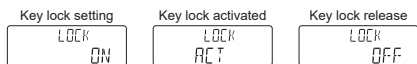

8 CAUTIONS

- For the controller DC power supply, only use a power supply that is isolated by means of an isolation transformer or otherwise.
- Risk of short-circuiting and damage to the controller or power supply if a transformer such as an auto transformer is used. Risk of short-circuiting and damage to the controller or power supply if incorrectly mounted or connected.
- The controller HG-SC□ is designed to be used with the special sensor head HG-S□. If used with other than the special sensor head option, the specifications will not be met and product malfunctioning or damage may occur.

- This product has been developed / produced for industrial use only.
- This product uses an EEPROM. The EEPROM has a service life of one million setting operations.
- Do not use this product outside the range of the specifications. Risk of an accident and product damage. There is also a risk of a noticeable reduction of service life.
- Verify that the supply voltage fluctuations are within the rating.
- If power is supplied from a commercial switching regulator, ensure that the frame ground (F.G.) terminal of the power supply is connected to an actual ground.
- Do not use during the initial transient time after the power supply is switched ON.
- Make sure that the power supply is OFF while performing wiring or connecting a slave unit work.
- Take care that short-circuit of the load or wrong wiring may burn or damage the product.
- After you have completed wiring work, check the wiring carefully before switching on the power.
- Do not wire in parallel with a high-voltage line or power line, or run through the same conduit. Risk malfunctioning due to induction.
- Do not apply stress such as excessive bending or pulling to the extracted part of a cable.
- This product is suitable for indoor use only.
- Avoid dust, dirt, and steam.
- Do not use this sensor in places where it may come into contact with corrosive gas, etc.
- Ensure that the product does not come into contact with organic solvents such as thinner.
- Ensure that the product does not come into contact with strong acid or alkaline.
- Ensure that the product does not come into contact with oil or grease.
- This product cannot be used in an environment containing flammable or explosive gases.
- Performance may not be satisfactory in a strong electromagnetic field.
- This product is a precision device. Do not drop or otherwise subject to shock. Risk of product damage.
- Never attempt to disassemble, repair, or modify the product.
- When the product becomes unusable or unneeded, dispose of the product appropriately as industrial waste.

9 SPECIFICATIONS

Type	Master unit		Slave unit		
	NPN output	PNP output	High performance type	Standard type	Wire-saving type
Model No.	HG-SC101	HG-SC101-P	HG-SC111	HG-SC112	HG-SC113
Number of connectable units	Up to 15 slave units can be connected per master unit. (When communication unit consolidated: up to 14 slave units)				
Supply voltage	24V DC ±10%, including 0.5V ripple (P-P)				
Current consumption (Note 2)	70mA or less (when sensor head is connected)				
Analog current output (Note 3)	• Current output range: 4 to 20mA / F.S. (default value) • Error output: 0mA • Linearity: ±0.25% F.S. • Load impedance: 250Ω MAX.		—		
Control output (Output 1 / Output 2 / Output 3)	<NPN output type> NPN open-collector transistor • Maximum sink current: 50mA (Note 4) • Applied voltage: 30V DC or less (between output and 0V) • Residual voltage: 1.5V or less (at 50mA sink current) • Leakage current: 0.1mA or less		<PNP output type> PNP open-collector transistor • Maximum source current: 50mA (Note 4) • Applied voltage: 30V DC or less (between output and +V) • Residual voltage: 1.5V or less (at 50mA source current) • Leakage current: 0.1mA or less		
Short-circuit protection	Incorporated (automatic reset type)				
Decision output	NO/NC switching type				
Alarm output	Open when alarm				
External input (Input 1 / Input 2 / Input 3)	<NPN output type> Non-contact input or NPN open-collector transistor • Input condition Invalid: +8V to +V DC or open Valid: 0 to +1.2V DC • Input impedance: Approx. 10kΩ		<PNP output type> Non-contact input or PNP open-collector transistor • Input condition Invalid: 0 to +0.6V DC or open Valid: +4V to +V DC • Input impedance: Approx. 10kΩ		
Trigger input	Input time 2ms or more (ON)				
Preset input	Input time 20ms or more (ON)				
Reset input	Input time 20ms or more (ON)				
Bank input A / B	Input time 20ms or more (ON)				
Response time	3ms, 5ms, 10ms, 100ms, 500ms, 1,000ms switching type				
Display resolution	0.1μm				
Display range	-199.9999 to 199.9999mm				
Protection	IP40 (IEC)				
Contamination level	2				
Ambient temperature	-10 to +50°C (No dew condensation or icing allowed) (Note 4), Storage: -20 to +60°C				
Ambient humidity	35 to 85% RH, Storage: 35 to 85% RH				
Elevation	2,000m or less (Note 5)				
Material	Case: Polycarbonate, Cover: Polycarbonate, Switches: Polycetal				
Cable	0.2mm ² 2-core (brown, blue lead wires) / 0.15mm ² 7-core composite cable, 2m long	0.15mm ² 7-core composite cable, 2m long	0.15mm ² 6-core cable, 2m long	—	
Weight (controller only)	Approx. 140g	Approx. 140g	Approx. 130g	Approx. 60g	

- Notes: (1) Measured at a supply voltage of +24V DC and an ambient temperature of +20°C, unless otherwise indicated.
 (2) Current consumption does not include analog current output.
 (3) Linearity F.S. = 16mA, and is linearity with respect to digitally measured values. Response time is the time following measured value update.
 (4) When slave units are connected to the master unit, the maximum sink current / source current of the control output and ambient temperature vary depending on the number of connected slave units as shown below.

Number of connected slave units	When communication unit consolidated	Maximum sink current / source current of control output	Ambient temperature
			-10 to +45°C
1 to 7 units	1 to 6 units	20mA	-10 to +45°C
8 to 15 units	7 to 14 units	10mA	

- (5) Do not use or store in an environment pressurized to atmospheric pressure or higher at an altitude of 0m.

10 ERROR DISPLAY

Error Display	Description	Action
E 100	Both NPN output types and PNP output types are connected.	Connect only units of the same output type.
E 110	Number of connectable units exceeded.	Connect no more than 15 slave units per master unit. (When communication unit consolidated: up to 14 slave units)
E 120	Cannot communicate between controllers.	Switch OFF the power, make sure the controllers are connected correctly, and then switch ON the power again.
E 130		
E 140	The calculation function is valid but no slave units are connected.	Change calculation mode to OFF.
E 150	The calculation function is valid but an insufficient number of slave units are connected.	Change calculation mode to OFF, or change the calculation application selection setting.
E 160	The saved number of connected units does not match the actual number of connected units.	Set the number of connected units check function to OFF.
E 200	• Sensor head not connected. • Broken wire in sensor head connection cable. • Sensor head failure.	• Check if the sensor head is correctly connected. • Check if there is a broken wire in the sensor head connection cable. If there is a broken wire in the sensor head connection cable, replace the cable. • Replace the sensor head.
E 210	The thrust on the sensor head stroke is above the specified range.	Check the sensor head mounting and measurement object installation position, and adjust so that the stroke is within the specified range.
E 500	Unable to preset by external input.	Check if the power just been switched on or reset has just been input, or if a display value is outside the display upper/lower limit or an alarm has occurred.
E 600	• Failed to write to or read from EEPROM. • The EEPROM write count is over the service life of 1 million.	• Switch the power OFF then ON, and execute initialization of the controller from setting mode. • If the controller does not recover after the above, it is possible that the EEPROM write count is over 1 million. Replace the controller.
E 610		
E 620		
E 700	The detection output load has short-circuited and excessive current is flowing.	Switch OFF the power and check the load.
E 900	An error has occurred in the internal controller.	Switch the power OFF then ON, and execute initialization of the controller from setting mode.
E 910		
E 911		
E 912		
E 920		

Panasonic Industrial Devices SUNX Co., Ltd.

<https://panasonic.net/id/pidsx/global>

Overseas Sales Division (Head Office)

2431-1 Ushiyama-cho, Kasugai-shi, Aichi, 486-0901, Japan
 Phone: +81-568-33-7861 FAX: +81-568-33-8591

For sales network, please visit our website.

PRINTED IN JAPAN

© Panasonic Industrial Devices SUNX Co., Ltd. 2019