REFERENCE SPECIFICATIONS

Product Name : AC servo driver
Model Number: MINAS-A5B Series M Size

Issued on
Apr. 6th, 2016
Revised on

Motor Business Unit, Electromechanical Control Business Division
Automotive & Industrial Systems Company, Panasonic Corporation

7-1-1 Morofuku, Daito-City, Osaka 574-0044, Japan

Phone : +81-72-871-1212

Fax : +81-72-870-3151

Contents

1. Scope	1
2. Model Number	2
3. Applicable Motor	2
4. Basic Specifications	3
5. Dimensions	4
6. Appearance and Part Names	5
7. Connectors	6
7-1 Power Supply Connectors CN102 , CN103	6
7-2 Motor Connector CN101	6
7-3 Encoder Connector CN104	6
7-4 USB Connector CN7	7
7-5 EtherCAT (ECAT) Connectors CN9 , CN10	7
7-6 I/O Connector CN1	8
8. Wiring	9
8-1 Cables and Maximum Lengths	9
8-2 Cable Side Connectors	9
8-3 Precautions for Wiring	10
9. Safety Precautions	16
10. Life and Warranty	20
10-1 Life Expectancy of the Driver	20
10-2 Warranty Period	20
11. Others	21
Specification for Each Model	

1. Scope

This document is the specification for M size model of servo driver MINAS-A5B series.

This product is for industrial equipment.

Don't use this product at general household.

<Software version>

This technical reference applies to the servo drivers compatible with software of the following version:

Version 1:Ver3.04

Version 2:Ver3.04

Version 3:Ver1.00

For the software version, confirm it by the setup support software PANATERM or other function.

<Related documents>

SX-DSV02472: Technical document - Functional specification -

SX-DSV02473: Technical document - EtherCAT communication specification -

*This servo driver includes different specifications in part from technical reference - Functional specification -.

For details, refer to the page 3 or later of appendix.

*If the description of related documents is different from this document, make this document a priority.

< Summary of EtherCAT >

EtherCAT is an abbreviated designation of Ethernet for Control Automation Technology and is open network communication between a master and slaves using real-time ethernet developed in Beckhoff Automation GmbH and is managed in ETG (EtherCAT Technology Group).

EtherCAT® is registered trademark and patented technology,
licensed by Beckhoff Automation GmbH, Germany.



<IMPORTANT>

- All rights reserved. No part of this publication may be reproduced or transmitted in any form without prior permission.
- Motor Business Unit, Panasonic Corporation reserves the right to make modifications and improvements to its products and/or documentation, including specifications and software, without prior notice.
- This product might be forced to upgrade according to the specifications change by ETG.
We do not have liability for expenses of such upgrades.

Operating Precautions

Pay a special attention to following items in order to prevent failure and degradation of the product.

- Implement the measure against static electricity and handle it with great caution.
- Do not touch the electronic component except the heat sink of the product when installing and carrying it.
- Do not touch the edge and corner of the connector and printed-circuit board of the driver.
- When the equipment is energized, do not touch the driver.
- Install in the metal control box in order to prevent malfunction by noises, such as the electromagnetic interference (EMI).
- Prevent foreign matter from getting into the product.
- Do not give the impact shock to the product.
- Do not add stress, such as the twist and bending, to the printed-circuit board of the product. Fix the cable so that stress is not added to the printed-circuit board and the connector of the product.

2. Model Number

The following shows how to interpret a model number.

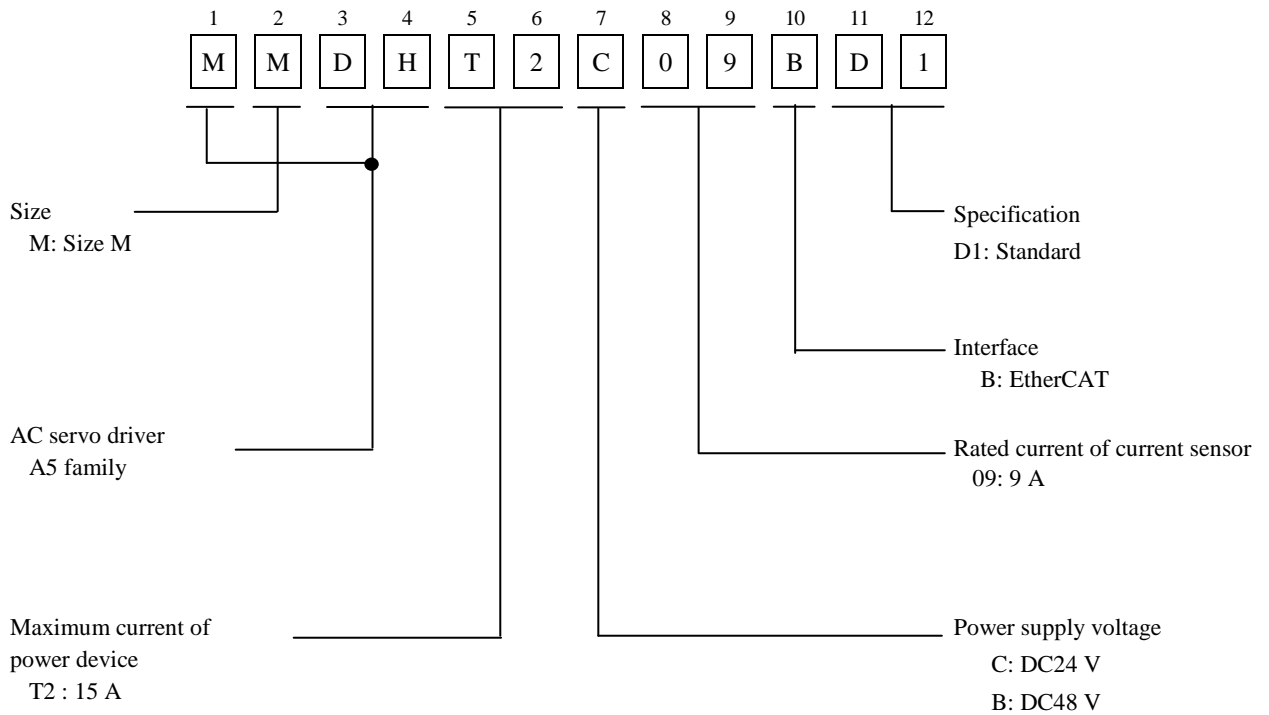

3. Applicable Motor

Driver			Applicable motor			
Model No.	Size	Power Supply	Model No.	Rated output	Rated speed	Encoder type
MMDHT2C09BD1	M	DC24 V	MMMA1ACF**	10 W	3000 r/min	Absolute 20bits resolution
			MMMA2ACF**	20 W	3000 r/min	Absolute 20bits resolution
			MMMA3ACF**	30 W	3000 r/min	Absolute 20bits resolution
			MNMA2ACF**	20 W	3000 r/min	Absolute 20bits resolution
MMDHT2B09BD1	M	DC48 V	MMMA1ABF**	10 W	3000 r/min	Absolute 20bits resolution
			MMMA2ABF**	20 W	3000 r/min	Absolute 20bits resolution
			MMMA3ABF**	30 W	3000 r/min	Absolute 20bits resolution
			MNMA2ABF**	20 W	3000 r/min	Absolute 20bits resolution

4. Basic Specifications

Item			Description		
Input power supply (Note 1)	DC24 V	Voltage permission ripple		DC24 V $\pm 10\%$	
		Capacity of power supply	Applicable motor	MMMA 10W	Rated current: 1.8 Arms Max current: 13 Ao-p
				MMMA 20W	Rated current: 3.1 Arms Max current: 11 Ao-p
				MMMA 30W	Rated current: 3.5 Arms Max current: 12 Ao-p
	MNMA 20W			Rated current: 3.1 Arms Max current: 14 Ao-p	
	DC48 V	Voltage permission ripple		DC48 V $\pm 10\%$	
		Capacity of power supply	Applicable motor	MMMA 10W	Rated current: 0.9 Arms Max current: 6 Ao-p
				MMMA 20W	Rated current: 1.6 Arms Max current: 11 Ao-p
MMMA 30W				Rated current: 1.9 Arms Max current: 11 Ao-p	
MNMA 20W	Rated current: 1.5 Arms Max current: 9 Ao-p				
Conditions	Temperature		Operation temperature: 0-55 degrees C Storage temperature: -20-65 degrees C Guarantee the maximum temperature: 80 degrees C 72 hours		
	Humidity		Operation and storage humidity 20-85 %RH or less (no condensation)		
	Height above the sea		1,000 meters or less		
	Vibration		5.88 m/s ² or less, 10-60 Hz Continuous operation at resonance point is not allowed. (Note 2)		
Protection rating			IP00 (Note 3)		

* Easier condensation occurs when the temperature is reduced.

(Note 1) DC power using stabilized power supply (SELV) are provided with reinforced insulation.

(Note 2) Do not install in a flexible region.

(Note 3) Protection rating of this servo driver is IP00 (No protection).

Make sure not to put the electric static discharge or the foreign matters such as dust when installing or handling the driver

5. Dimensions

Size M

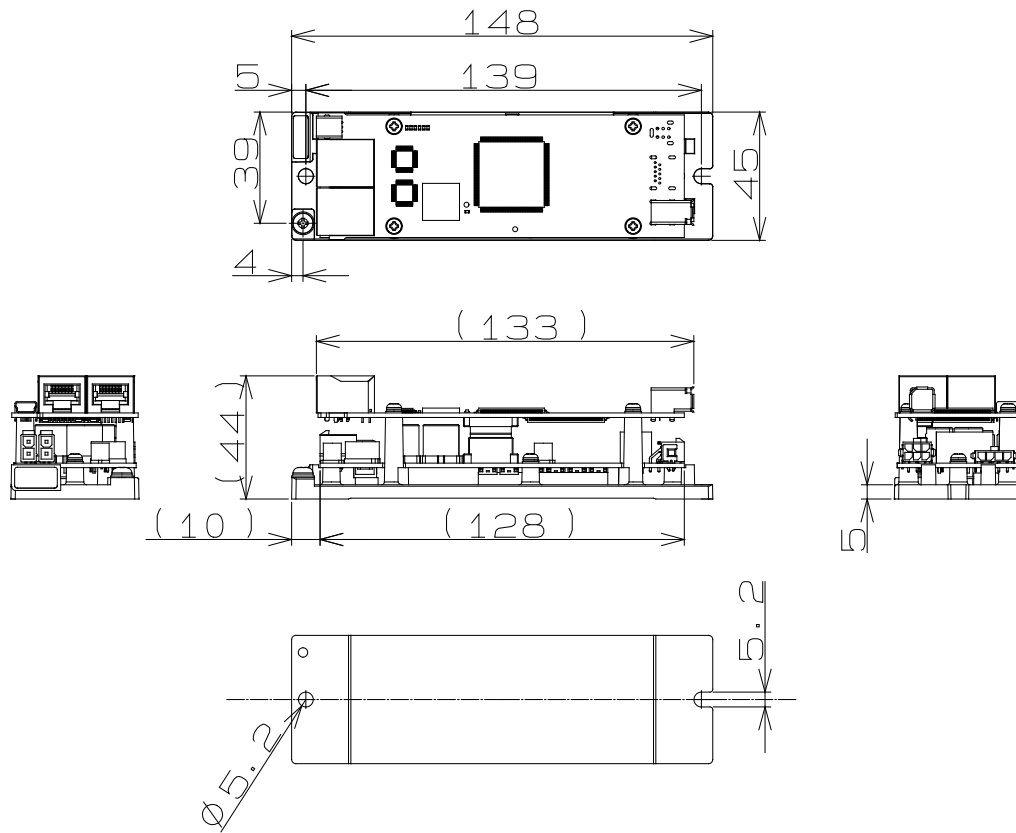

Unit : mm

6. Appearance and Part Names

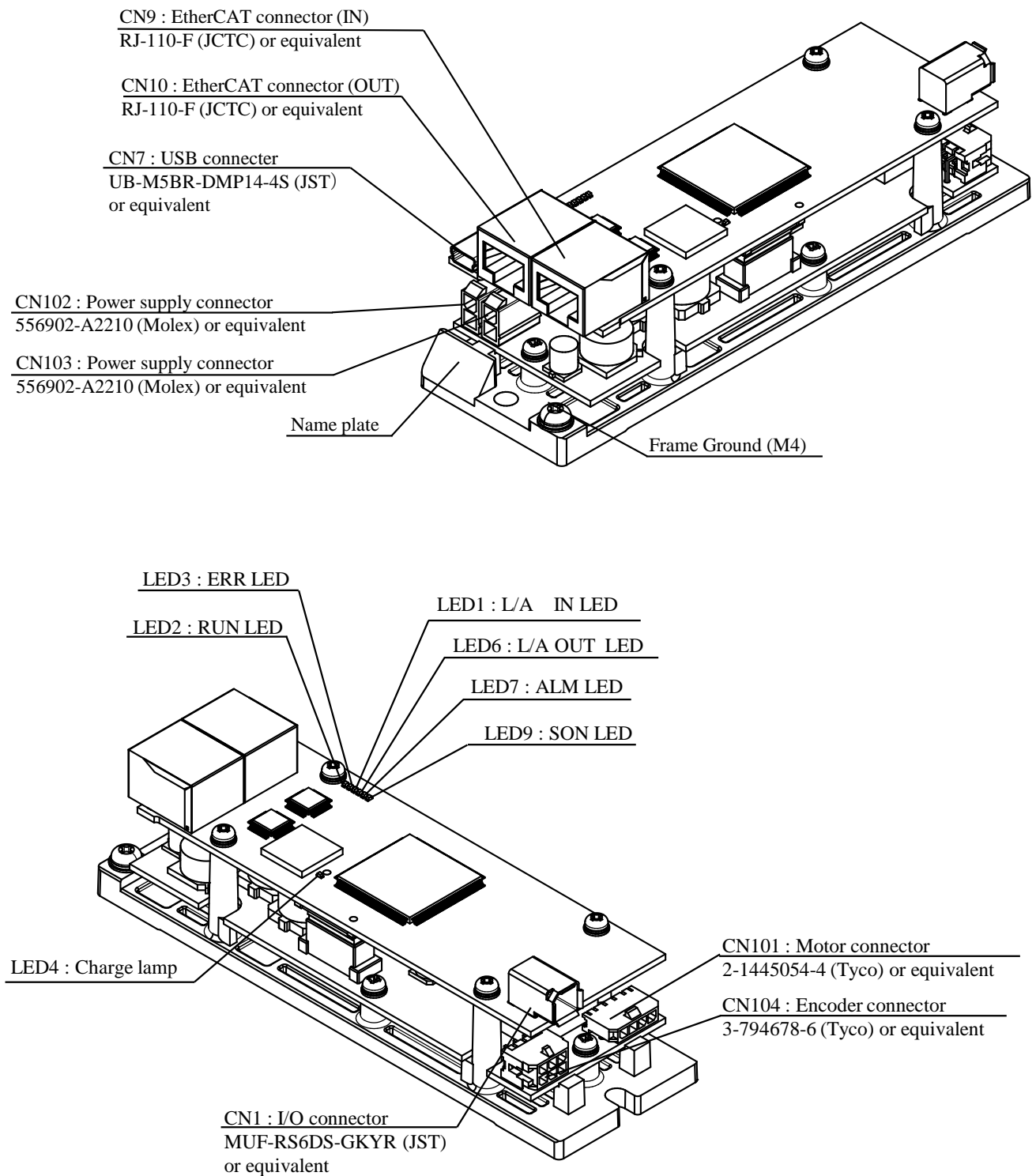

7. Connectors

7-1 Power Supply Connectors CN102, CN103

Servo driver side : Molex 556902-A2210 equivalent, Plating : TIN

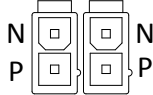
Pin no.	Symbol	Description	Layout
1	P (+ Line)	<ul style="list-style-type: none"> • Input DC24 V or DC48 V. • DC power source using a stabilized power supply are provided with reinforced insulation. 	
2	N (- Line)		

* There is no anti-connection function on the driver.

Reverse connection is caused of failure.

Enough attention to the power supply wiring.

* This servo driver has two power connectors, in order to install two or more daisy chain connection.

In that case, be sure not to exceed the maximum current (9 A) of these connectors.

7-2 Moter Connector CN101

Servo driver side : Tyco Electronics 2-1445054-4 equivalent, Plating : TIN

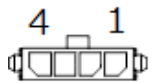
Pin no.	Symbol	Description	Layout
1	U	Connect U phase of the motor winding	
2	V	Connect V phase of the motor winding	
3	W	Connect W phase of the motor winding	
4	FG	Connect ground wire of the motor	

7-3 Encoder Connector CN104

Servo driver side : Tyco Electronics 3-794678-6 equivalent, Plating : GOLD

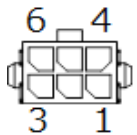
Pin no.	Symbol	Description	Layout
1	NC	NC (No connection)	
2	PS	Encoder signal I/O (serial signal)	
3	$\overline{\text{PS}}$		
4	E5V	Power supply output for encoder	
5	E0V		
6	FG	Frame ground	

7-4 USB Connector CN7

Servo driver side : J. S. T. Mfg UB-M5BR-DMP14-4S equivalent, Plating : GOLD

By connecting to the PC through USB interface, various operations such as setting / changing of parameters, monitoring of control state, referencing of error/history, and saving/loading of parameters can be performed.

Pin no.	Symbol	Description
1	VBUS	USB communication signal
2	D-	
3	D+	
4	-	NC (No connection)
5	GND	Signal ground

<About the USB cable>

Use a commercial-release USB cable with a ferrite core.

Connector of the servo driver side is a mini-B.

For the connector of a computer side, use it united with the specification of the computer to be used.

7-5 EtherCAT (ECAT) Connectors CN9, CN10

For EtherCAT, use RJ45 connector

Name	Symbol	Connector pin no.	Description
Transmit/Receive +	TX/RX+	1	Connect to pin 1 on the RJ45 connector of communicating node
Transmit/Receive -	TX/RX-	2	Connect to pin 2 on the RJ45 connector of communicating node
Receive/Transmit +	RX/TX+	3	Connect to pin 3 on the RJ45 connector of communicating node
Not used	-	4	Connect to pin 4 on the RJ45 connector of communicating node
Not used	-	5	Connect to pin 5 on the RJ45 connector of communicating node
Receive/Transmit -	RX/TX-	6	Connect to pin 6 on the RJ45 connector of communicating node
Not used	-	7	Connect to pin 7 on the RJ45 connector of communicating node
Not used	-	8	Connect to pin 8 on the RJ45 connector of communicating node
Frame ground	FG	Shell	Connect to shield of cable.

- Be sure to use shielded twisted pair (STP) compatible with 5e of TIA/EIA-568 or higher category.
- The final pin function for pins 1, 2, 3, and 6 are determined by Auto MDI-X.

7-6 I/O Connector **CN1**

Servo driver side : J. S. T. Mfg MUF-RS6DS-GKYR equivalent, Plating : GOLD

Input

Pin no.	Symbol	Description	I/O type	layout
3	I-COM	<ul style="list-style-type: none"> Connect to positive/negative polarity of the external power supply. Use power supply: 12 V +/-5 % to 24 V +/-5 % 	-	
4	SI5	<ul style="list-style-type: none"> Assign functions using parameters. 	i-1	
5	SI6	<ul style="list-style-type: none"> For details, refer to the technical data - Basic function specification - SX-DSV02472. 	i-1	
6	SI7	<ul style="list-style-type: none"> For factory default function assignment, refer to appendix "Specification for Each Model". 	i-1	

(Note) SI1-SI4 and SI8 cannot be used with this servo driver.

Output

Pin no.	Symbol	Description	I/O type	layout
1 2	SO1+ SO1-	<ul style="list-style-type: none"> Assign functions using parameters. For details, refer to the technical data—Basic function specification—SX-DSV02472. For factory default function assignment, refer to appendix "Specification for Each Model". 	o-1	see the above

(Note) SO2-SO3 cannot be used with this servo driver.

Other

Pin no.	Symbol	Description	I/O type
Shell	FG	<ul style="list-style-type: none"> Connected to the Frame ground inside the servo driver. 	-

I/O interface type

i-1

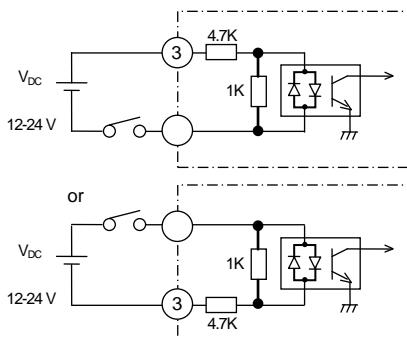

o-1

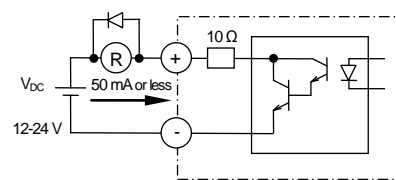

Note: To directly run the relay, attach a diode in parallel with the relay and in the direction shown in the figure above.
VCE sat = 1.2 V

8. Wiring

8-1 Cables and Maximum Lengths

Name	Symbol	Maximum cable length	Cable
Power connection	CN102 CN103	-	AWG 18
Motor connection	CN101	3 m	AWG 20
Encoder connection	CN104	3 m	Overall twisted shielded pair Core wire: 0.18 mm ² or larger
I/O connection	CN1	1 m	
ECAT connection	CN9 CN10	100 m (Note 1)	Shielded twisted pair (STP) cable of category 5e or better

(Note 1) Refer to 8-3 (7) Connection to connectors CN9, CN10.

8-2 Cable Side Connectors

Symbol	Part name	Part number	Manufacturer
CN102 CN103	Connector	5557-02R	Molex
	Pin	5556TL	
CN101	Connector	1445022-4	Tyco Electronics
	Pin	794610-1	
	Connector	43645-0400	Molex
	Pin	43030-0001	
CN104	Connector	794617-6	Tyco Electronics
	Pin	794611-3	
	Connector	43025-0600	Molex
	Pin	43030-0002	
CN1	Connector	MUF-PK6W-Y	J. S. T. Mfg

Use connectors listed above or equivalents.

8-3 Precautions for Wiring

(1) Wiring to power connector

- [1] Power connector of the servo driver is tin plated. In order to avoid a bad contact caused by dissimilar metals, connector pins for the connection, please use the tin plating.
- [2] The DC power supply might have a trip to protect its components from over-voltage that is caused by the regenerated energy from motor. In that case, it is necessary to install the diode for protecting from the feedback current and also to install the DC bus capacitor for storing the regenerated energy between the DC power supply and drivers.
- [3] So that the specified voltage at the input servo driver, consider the transient voltage drop due to the impedance wiring, select both the diameter of the power line and the length.
- [4] This servo driver does not mount the inrush current limit circuit. Inrush current is dependent on the characteristics and wiring impedance of the connection power, please check the actual machine.
- [5] Because this servo driver to assume a connection with a stabilized power supply is provided with reinforced insulation, protective ground terminal is not available. M4 screw on the heat-sink is functional earth (FG). Considerations of noise resistance, static electricity, noise radiation, please give a connection on the FG of equipment side as necessary.

(2) Wiring to motor connector

- [1] Motor connector of the servo driver is tin plated. In order to avoid a bad contact caused by dissimilar metals, connector pins for the connection, please use the tin plating.
- [2] For a noise countermeasure, attach the ferrite core U, V, W as necessary.

(3) Wiring to encoder connector

- [1] Encoder connector of the servo driver is gold plated. In order to avoid a bad contact caused by dissimilar metals, connector pins for the connection, please use the gold plating.
- [2] For the encoder cable is a stranded wire of core wire, please use Collective shield twisted pair cable.
- [3] Maximum cable length is within 3 m. In order to meet the mitigation of the voltage drop of 5 V power supply to the encoder to long wiring, select the appropriate wire diameter.
- [4] Encoder cable should be located well away from power cable and motor cable with large current.

(4) Wiring to I/O connector

- [1] I/O connector of the servo driver is gold plated. In order to avoid a bad contact caused by dissimilar metals, connector pins for the connection, please use the gold plating.
- [2] Do not exceed the maximum voltage and current specification of the input and output.

(5) Wiring to connector **CN1**

- [1] The DC12–24 V power supply for the external control signal connected to the I-COM should be prepared by the customer.
- [2] Place the servo driver and its peripheral device as nearly as possible (up to 3 m) so as to shorten the wiring.
- [3] Wire the wiring as far away as possible (30 cm or more) from the power lines (P, N, U, V, W).
Do not put them in the same duct or bind them together.

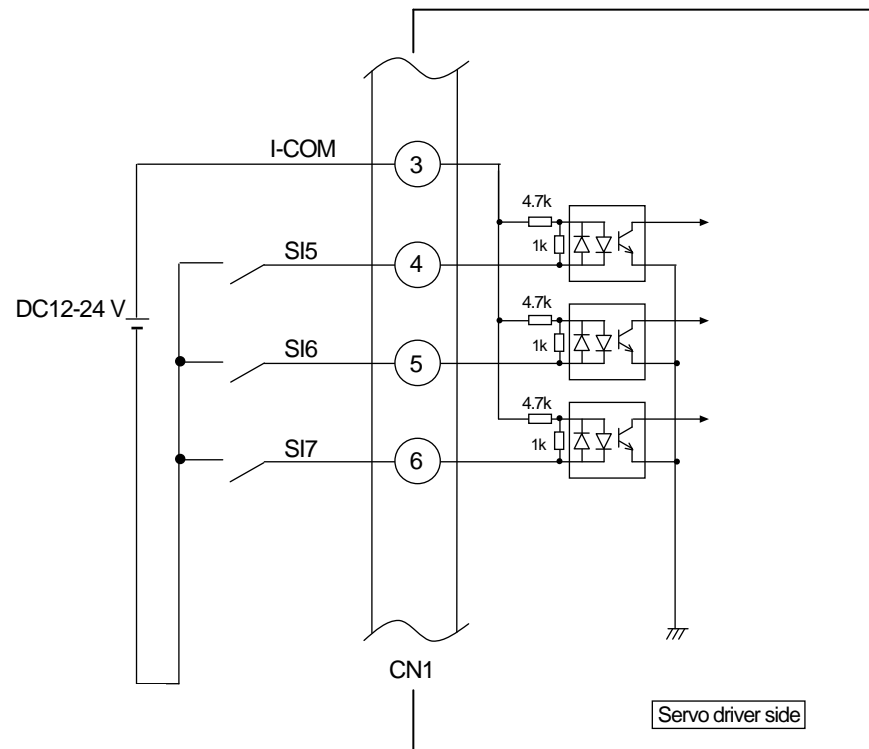
Input

The functions of the pins SI5-SI7 are assigned by parameters. For factory default settings, refer to Appendix “Specification for Each Model”.

Output

- [4] Be aware of the polarity of the power supply for control signals. The servo driver is damaged by reverse connection of the polarity shown in the following figure.
- [5] To directly drive the relay with each output signal, make sure to attach a diode in parallel to the relay and in the direction as shown in the figure below. The servo driver can be damaged if the diode is not attached or the diode is attached in the reverse direction.
- [6] Apply 50 mA or less of current to output.

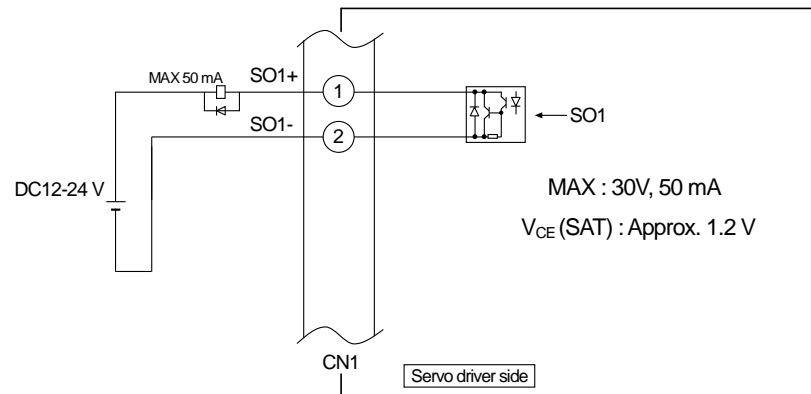

The functions of the pins SO1 are assigned by parameters. For factory default settings, refer to Appendix “Specification for Each Model”.

(6) Wiring to connector **CN104**

- [1] As for the encoder cable, use the batch shielded twisted wire pairs whose core is 0.18 mm² or more.
- [2] The cable length should be up to 3 m. When the wiring is long, use the double wiring for the 5 V power supply in order to reduce the effects of voltage drop.
- [3] Make sure to connect the coat of shielded cable at the servo driver side to the FG (6-pin) of **CN104**.
- [4] Wire the wiring as far away as possible (30 cm or more) from the power lines (P, N, U, V, W).
Do not put them in the same duct or bind them together.
- [5] Do not connect anything to the empty pins of **CN104**.

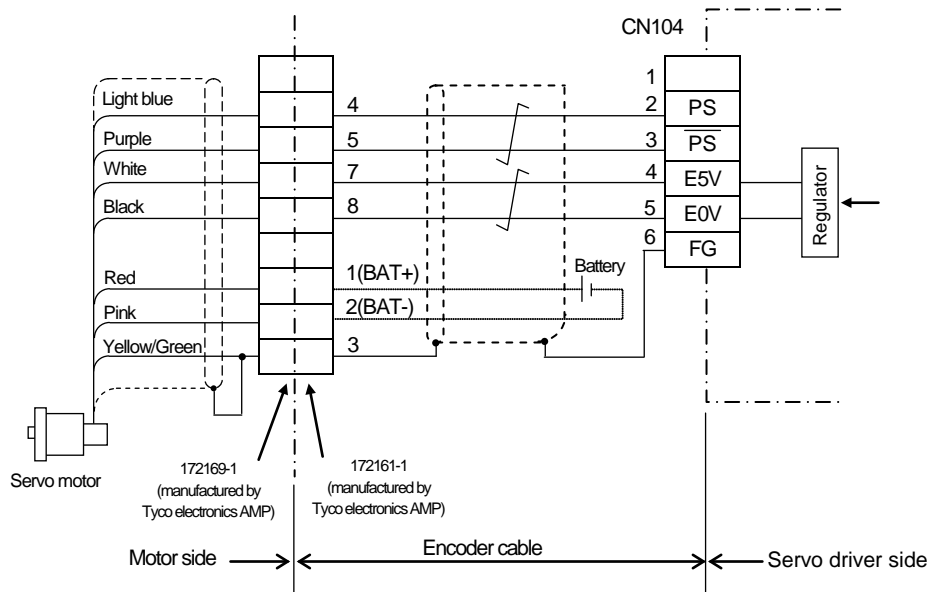
Absolute 20bits encoder

Connect the absolute encoder battery directly to the BAT+ and BAT- connectors of the encoder at the motor for the absolute system.

Precautions in using a battery for absolute encoder

An error arises from the absolute encoder when a battery voltage drop occurs.
The voltage drop occurs due to the life span of a battery or voltage delay.

- (1) The life span of a battery may become short depending on ambient environment.
- (2) Lithium batteries have a transient minimum voltage effect (voltage delay phenomenon), in which a voltage drop may occur temporarily when discharge starts. For this reason, the batteries should be refreshed when used.

<When a battery is used for the first time>

Before using our optional battery unit DV0P2990, connect the connector with lead wires to the battery as shown in the right figure and leave it for about 5 minutes.
And then disconnect the connector from the CN601, and install it to the servo driver.

If using another battery, we recommend that you also refresh the battery. For refreshing a battery, consult with the manufacturer of the battery.

<After installing battery>

We recommend that control power be turned on/off once a day.

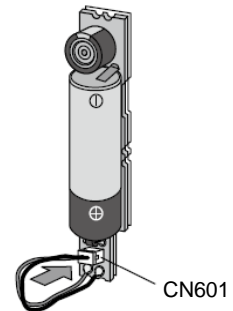

Other precautions

- If used incorrectly, batteries may cause troubles such as corrosion due to leakage and hazards such as explosion. So, observe the following rules:
 - [1] Insert a battery correctly without confusing + and - terminals.
 - [2] If a battery used for a long time or no longer used is left inside equipment, a trouble such as leakage may occur. Replace such a battery as soon as possible. (As a standard, we recommend replacing batteries every 2 years.)
 - The battery electrolyte is highly corrosive. It not only corrodes surrounding parts, but it also causes hazards such as a short-circuit due to its conductivity. Replace batteries periodically.
 - [3] Do not disassemble batteries or throw them into fire.
 - Do not disassemble the battery because it is very dangerous if a splash of the contents comes into an eye. Also, do not throw the battery into fire or heat it because it may burst, causing hazards.
 - [4] Do not short-circuit the battery or remove its tube.
 - If the battery + and - terminals are connected together with a conductive material such as a metal, a large current flows, not only weakening the battery, but also generating excessive heat, resulting in a burst to cause hazards.
 - [5] Never attempt to charge the battery because it is not rechargeable.
- Disposal of old batteries after replacement may be restricted by local governments. Dispose of batteries following such a restriction.
- Air transportation

Application for approval of hazardous material air transportation is required (for both passenger and cargo airplanes). (UN packing is required.)

When you ask for air transportation, you are requested to submit necessary documents (parameter sheets and MSDS etc.). In this case, make a request to us through a dealer you purchased from.
- UN packing

Consult with your transport company.

(7) Wiring to connector **CN9**, **CN10**

[1] Use straight type of 8core 4pairs shielded twisted pair (STP) compatible with category 5e of TIA/EIA-568 or higher specifications.

When installing connector plug on both ends of shielded cable, positively connect the shield to the metallic plug shell. If connection is not proper, EMC characteristic could degrade.

For colors of wire and matching connector pins, refer to TIA/EIA568B (see figure below).

Connect a cable before supplying the power to the driver. Do not pull or insert a cable after supplying the power to the driver.

PIN 1, 2, 3 and 6 are signal lines. The unused PIN 4, 5, 7 and 8 also need to be connected.

[2] Length of communication cable

Between 2 nodes: max. 100 m

Because specifications such as flexural characteristic, temperature range and insulation material differ from manufacturer to manufacturer, select the cable best suitable for your application.

Select the cable for movable application according to your operating condition.

<Communication cable used in our evaluation>

Manufacturer: Sanwa Supply Inc.

Part No.: KB-STP-*LN, Category: 5e, STP

Connection to CN9 / CN10

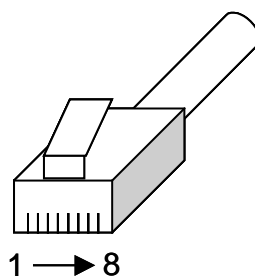
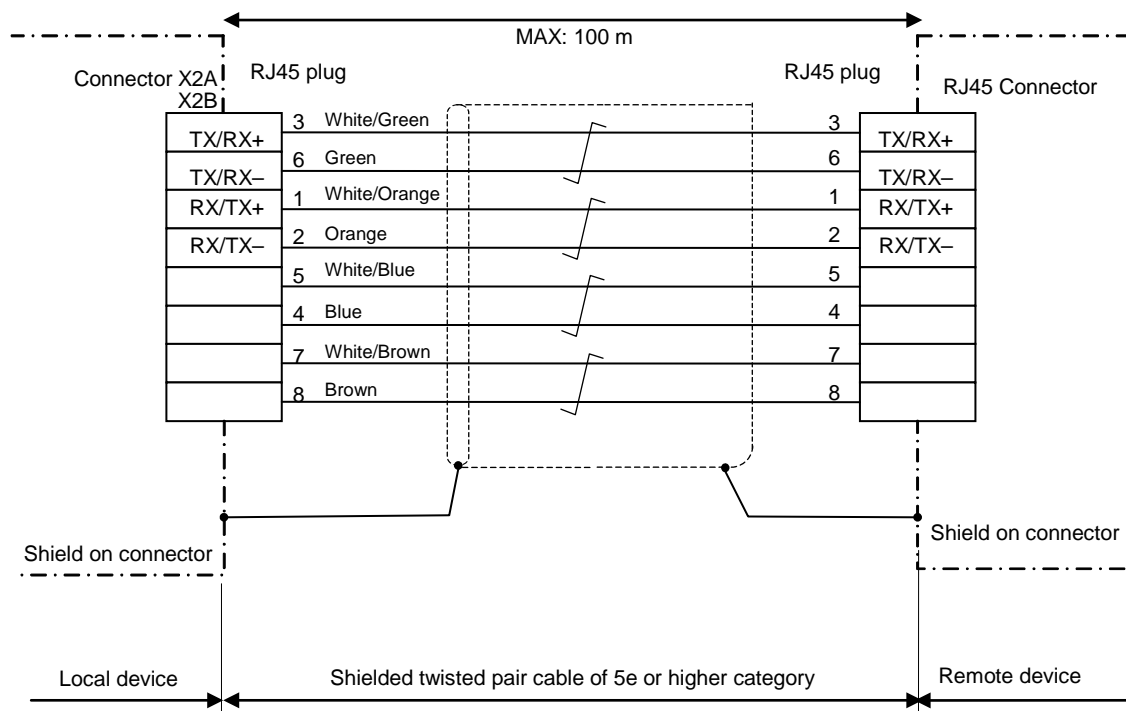

Pins on RJ45 plug



SAFETY PRECAUTIONS

9. Safety Precautions

- Danger and damage caused when the safety precautions are ignored are described in the following categories and signs:

DANGER	Description of this sign indicates “urgent danger that may cause death or serious injury.”
CAUTION	Description of this sign indicates “danger that may cause injury or property damage.”

- Rules to keep are categorized and described with the following graphics.

	This graphic indicates “Prohibited” acts that are not permitted.
	This graphic indicates “Mandatory” acts that must be performed forcibly.



DANGER



- (1) Be sure not to store or use the equipment under conditions subjected to vibrations (5.88 m/s² or heavier) or an impact shock, foreign matters such as dust, metal particles oil mist, liquids such as water, oil and polishing liquid, near flammable objects, in an atmosphere of corrosive gas (such as H₂S, SO₂, NO₂, Cl₂), or in an atmosphere of flammable gas.
- (2) Do not place any flammable objects near a motor, a servo driver.
- (3) Do not drive the motor with an external force.
- (4) Do not damage or strain the cable, or do not apply excessive stress. Do not place a heavy item on the cable or do not pinch the cable.
- (5) Do not use the equipment with the cable soaked in oil or water.
- (6) Do not install the equipment near a heating object such as a heater or a large wire-wound resistor. (Install a thermal shield, etc. to avoid the influences of heating object.)
- (7) Do not connect the motor directly with a commercial power.
- (8) Do not use the equipment under conditions subject to strong vibrations or an impact shock.
- (9) Be sure not to touch a rotating part of a motor during operation.
- (10) Do not touch the key flutes of motor output shaft with bare hands.
- (11) Be sure not to touch inside a servo driver.
- (12) Motor servo driver heat sink and peripheral device become very hot. Do not touch them.
- (13) Do not carry out wiring or do not operate the equipment with wet hands.
- (14) Wiring work is strictly allowed only for an engineer specializing electrical work.



SAFETY PRECAUTIONS



- (15) A motor other than specified is not provided with a protection device. Protect a motor with an overcurrent protection device, a ground-fault interrupter, overheating protection device, and emergency stop device, etc.
- (16) When operating the servo driver after an earthquake, inspect installation conditions of the servo driver and the motor and safety of the equipment to make sure that no fault exists.
- (17) After turning off the power, the inside circuit remains charged at a high voltage for a while. When moving, wiring or inspection the equipment, completely shut off the power supply input outside the servo driver and leave for 15 minutes or longer before working.
- (18) Install and mount the equipment securely to prevent personal injury caused by poor installation or mounting on an earthquake.
- (19) Install an external emergency shutoff circuit to stop operation and interrupt power immediately upon emergency.
Emission of smoke or dust may occur due to a fault of a motor or a servo driver used in combination.
- (20) Mount the motor, the servo driver and the peripheral devices on a noncombustible material such as metal.
- (21) IN consideration of strength of the screws and the material of the mounting base, select appropriate fastening torque for the product mounting screws, so that the screws will not be loosened or damaged.

Example)To tighten a steel screw into a steel base. M5:2.7 to 3.3 N·m
- (22) Provide correct and secure wiring. Insecure wiring or incorrect wiring may cause runaway or burning of a motor. During wiring work, avoid entry of conductive dust such as wire chippings in a servo driver.
- (23) Connect cables securely and provide secure insulation on current-carrying parts using insulation material.
- (24) FG screw (M4) should be tighten to a torque of 1.0 ~ 1.2 N • m.



CAUTION



- (25) Do not hold cables or motor shaft when carrying the equipment.
- (26) Do not adjust or change servo driver gains extremely, and do not make operations of the machine instable.
- (27) The equipment may suddenly restart after recovery from shutdown upon a power failure. Keep away from the equipment.
Specify settings of the equipment to secure safety for human against such restart operations.
- (28) When the equipment is energized, keep away from the motor and mechanism driven by the motor in case of malfunction.
- (29) Avoid a strong shock to the motor shaft.
- (30) Avoid a strong shock to the product.
- (31) Be sure not to use the electromagnetic contactor installed on the power supply to start or stop the motor.
- (32) Avoid frequent switching on and off the main power supply of the servo driver.
- (33) The built-in brake of the motor is used for holding only. Do not use the brake to stop (braking) for securing safety of the equipment.
- (34) Do not fall or topple over the equipment when carrying or installing.



SAFETY PRECAUTIONS



CAUTION



- (35) Do not climb the motor or do not place a heavy item on the motor.
- (36) Do not put a foreign matter into the servo driver.
- (37) Do not use the equipment under direct sunlight. When storing the equipment, avoid direct sunlight and store under conditions of operating temperatures and humidity.
- (38) Be sure not to disassemble or modify the equipment.
Disassembling and repair is allowed only for the manufacturer or sales agency authorized by the manufacturer.
- (39) Please use power are provided with reinforced insulation the stabilized power supply (SELV). Do not connect the positive side and the negative side and ground (FG) of the input power of servo driver.
- (40) This servo driver is Built-in type (degree of protection IP00). Please note that during the installation so without applying static electricity. Static electricity is applied to runaway or burning, destruction, and cause of failure.



- (41) Use a motor and a servo driver in combination specified by the manufacturer. A customer shall be responsible for verifying performances and safety of combination with other servo driver.
- (42) A failure of a motor or a combined servo driver may cause burning of motor, or emission of smoke and dust. Take this into consideration when the application of the machine is clean room related.
- (43) Install the equipment adequately in consideration of output and main unit weight.
- (44) Keep the ambient conditions of an installed motor within a range of allowable ambient temperatures and of allowable humidity.
- (45) Install the equipment by specified procedures and in specified orientation.
- (46) Install the devices by keeping specified distances between a servo driver and inside control panel or other devices.
- (47) If a motor has an eyebolt, use the eyebolt to carry the motor only. Do not use the eyebolt to carry equipment.
- (48) Connect a relay breaking upon emergency stop in series with a brake control relay.
- (49) For a test run, hold down a motor and disconnect from a mechanical system to verify operations before installing on the equipment. (A motor must run smoothly at 30 r/min driven with a servo driver.)
- (50) Verify that an input power supply voltage satisfies the servo driver specifications before turning on the power and start operation.
An input voltage higher than rated may cause ignition and smoking in the servo driver, which may cause runaway or burning of a motor in some cases.
- (51) When an alarm status occurs, remove a cause of the problem before restarting.
Careless restarting without removing a cause of problem may cause malfunction or burning of a motor.
- (52) The built-in brake of the motor may not be able to hold due to expiring useful life or a mechanical structure. Install a braking device on the equipment to secure safety.
- (53) Pay attention to heat radiation. The servo driver generates heat by operating a motor. A servo driver used in a sealed control box may cause an extreme rise of temperature.
Consider cooling so that an ambient temperature around the servo driver satisfies an operating range.
- (54) Maintenance and inspection is allowed only for a specializing person.
- (55) Turn off the power when the equipment is not used for a long term.

- Capacitance of the capacitors of power supply rectifier circuit drops over time. To avoid a secondary problem due to a failure, replacement of capacitors is recommended at an interval of approximately 5 years. Commission the manufacturer or sales agency authorized by the manufacturer to replace the parts.
- Be sure to read the operating manual (safety book) before use.



SAFETY PRECAUTIONS

Servo driver's ambient temperature

The driver's service life significantly depends on the ambient temperature.

Do measures cooling such as fan installation.

Operating temperature range: 0 to 55 degrees C

We have made the best efforts to ensure quality of this product. However, application of external noise (include radiation) or static electricity, or a defect of the input power supply, wiring or components may cause the servo driver to operate beyond the preset conditions. Therefore, you should exercise thorough caution to ensure safety against an unexpected operation.

10. Life and Warranty

10-1 Life Expectancy of the Driver

The Servo driver has 28,000 hours of life expectancy when used continuously under the following conditions.

Definition of the life Life end shall be defined as the capacitance of the electrolytic capacitor is reduced by 20 % from the ex-factory status.

Condition	{	Input power source: DC 24 V / DC48V Ambient temperature: 55 degree C Output torque: Rated constant value Number of revolutions: Rated constant Number of revolutions
-----------	---	---

Note that the life varies due to the working conditions.

10-2 Warranty Period

(1) Warranty period

For a period of 12 months from the date of delivery or 18 months from the manufacturing month, whichever is shorter.

This warranty shall be exempted in the following cases,

- [1] defects resulting from misuse and/or repair or modification by the customer
- [2] defects resulting from drop of the product or damage during transportation
- [3] defects resulting from improper usage of the product beyond the specifications
- [4] defects resulting from fire, earthquake, lightning, flood, damage from salt, abnormal voltage or other act of God, or other disaster.
- [5] defects resulting from the intrusion of foreign material to the product, such as water, oil or metallic particles.

This warranty shall be exempted when the life of component exceeds its rated standard life.

(2) Warranty scope

Panasonic warrants the replacement of the defected parts of the product or repair of them when the defects of the product occur during the warranty period, and when the defects are under Panasonic responsibility. This warranty only covers the product itself and does not cover any damage incurred by such defects.

11. Others

- Precautions for export of this product and the equipment incorporating this product If the end user or end purpose of this product relates to military affairs, armament and so on, this product may be subject to the export regulations prescribed in “Foreign Exchange and Foreign Trade Control Law”. To export this product, take thorough examination, and follow the required export procedure.
- We cannot warrant this product, if it is used beyond the specified operating conditions.
- Compliance with the relevant standards should be considered by the user.
- The final decision on the compatibility with the installations and components at the user’s site, in terms of structure, dimensions, characteristics and other conditions, should be made by the user.
- When using this product in your equipment, be careful about the compatibility with the servo motor and the servo driver to be used together.
- For performance improvement or other reasons, some components of this product may be modified in a range that satisfies the specifications given in this document.
- Any specification change shall be based on our authorized specifications or the documents presented by the user. If a specification change may affect the functions and characteristics of this product, we will produce a trial product, and conduct examination in advance. Note that the produce price may be changed with a change in its specifications.
- We have made the best efforts to ensure the product quality. However, complete equipment at customer’s site may malfunction due to a failure of this product. Therefore, take precautions by providing fail-safe design at customer’s site, and ensure safety within the operating range of the work place.
- Failure of this product depending on its content, may generate smoke of about one cigarette. Take this into consideration when the application of the machine is clean room related.
- When the equipment runs without connecting the servomotor’s shaft electrically to ground, electrolytic corrosion may occur on the motor bearing and the bearing noise may get louder depending on the equipment and installing environment. So, customer is responsible to check and verify it.
- A customer must verify and inspect the equipment. Please be careful when using in an environment with high concentrations of sulphur or sulphuric gases, as sulphuration can lead to disconnection from the chip resistor or a poor contact connection.
- Take care to avoid inputting a supply voltage which significantly exceeds the rated range to the power supply of this product. Failure to heed this caution may result in damage to the internal parts, causing smoking and/or a fire and other trouble.
- When discard batteries, provide insulation using a tape etc. and discard the batteries abiding by a municipal law.
- This production is designed for general industry applications, and is not designed for applications of nuclear plant, aerospace, transportation, medical, various safety equipments, highly clean equipments that involve human lives, or for usage under special environment.
- When discarding the equipment, process the item as an industrial waste.

Specification for Each Model

● MINAS-A5B Series Size M

Model	MMDHT2C09BD1	MMDHT2B09BD1
Power supply input	DC24 V	DC48 V
Maximum instantaneous output current	15 A	15 A
Maximum continuous output current	9 A	9 A
Regenerative processing function	Unprovided	Unprovided
Auto gain tuning function	Provided	Provided
Dynamic brake function	Provided	Provided
Ambient temperature	0–55 degrees C	0–55 degrees C
Main power supply cable	HVSF 0.75–2.0 mm ²	HVSF 0.75–2.0 mm ²
	AWG 14–18	AWG 14–18
Ground cable	HVSF 2.0 mm ²	HVSF 2.0 mm ²
	AWG 14	AWG 14
Motor cable	HVSF 0.50 mm ²	HVSF 0.50 mm ²
	AWG 20 (5 A rated)	AWG 20 (5 A rated)
Inrush Current	No limit by driver	No limit by driver
Weight	Approx. 0.2 kg	Approx. 0.2 kg
Dimensions	Size M	Size M

I/O connector (CN1) default function allocation

CN1 connector		Default function			
Name	Pin number	Signal name	Parameter setting (): decimal notation	Symbol	Logic
SI5	4	Home	00222222h (2236962)	HOME	Normally open
SI6	5	Positive overtravel	00010101h (65793)	POT	Normally open
SI7	6	Negative overtravel	00020202h (131586)	NOT	Normally open
SO1	1,2	Motor brake release	00030303h (197379)	BRK-OFF	Normally open

Differences of Specification

This servo driver differs in the following specification to SX-DSV02472 technical documents (- Functional specification -).

■ Basic Specification

Item	Description	
Control mode	Full-closed control is not supported.	
Encoder feedback	20bits resolution 7-wire absolute encoder	
External scale feedback	Not supported.	
Control signal	Input	3-input can be assigned any function with the parameter.
	Output	1-output can be assigned any function with the parameter.
Pulse signal	Output	Not supported.
Safety terminal	Not supported.	
Front panel	Equipped with the followings on the PCB instead of the front panel. 1. RUN (See the below) 2. ERR (See the below) 3.L/A IN LED (See the below) 4.L/A OUT LED (See the below) 5. ALM LED (See the below) 6. SON LED (See the below)	
Regeneration	Not supported.	
Dynamic brake	Built-in	

■LED Display

1) RUN

RUN Indicator will show the status of ESM (Ether State Machine)

Indication is lighted in green.

LED	Content
OFF	ESM: INIT
Blinking	ESM: Pre-Operational
Single flash	ESM: Safe-Operational
ON	ESM: Operational

2) ERR

ERR Indicator will show the state of defined by AL status code. *1)

Indication is lighted in red.

LED	Content
OFF	With no generating of the alarm by AL Status *1)
Blinking	Communication setting error
Single flash	Synchronize event error
Double flash	Application watch dog time out
Flickering	Initialize error
ON	PDI error

*1) “ The alarm defined by AL status code” is which indicate Err80.0-7 and Err81.0-7 in the EtherCAT communication related error

3) L/A IN

4) L/A OUT

L/A IN, L/A OUT indicator will show the LINK status and operation status of Each port's physical layer.

Indication is lighted in green.

LED	Content
OFF	LINK not established
Flickering	LINK established. There are data transmission and reception
ON	LINK established. There are no data transmission and reception.

SON LED

Display status		Description
LED9	Lit green	Servo ON
	Not lit	Servo OFF

ALM LED

Display status		Description
LED7	Not lit	Normally
	Lit red	Alarm occurs

This servo driver does not support the following protective and warning functions.

■ Protective functions

Error No.		Description
Main	Sub	
13	1	Main power supply undervoltage protection
14	1	IPM error protection
18	0	Over-regeneration load protection
	1	Over-regeneration Tr error protection
25	0	Hybrid deviation excess error protection
28	0	Limit of pulse replay error protection
29	1	Deviation counter overflow protection 1
30	0	Safety detection
33	0	Overlaps allocation error 1 protection
	2	Input function number error 1 protection
	4	Output function number error 1 protection
50	0	External scale connection error protection
	1	External scale communication error protection
51	0	External scale status 0 error protection
	1	External scale status 1 error protection
	2	External scale status 2 error protection
	3	External scale status 3 error protection
	4	External scale status 4 error protection
	5	External scale status 5 error protection
55	0	A-phase connection error protection
	1	B-phase connection error protection
	2	Z-phase connection error protection
92	1	External scale data recovery error protection
93	2	Parameter setting error protection 2
	3	External scale connection error protection

■ Warning functions

	Warning No. (Hex.)	Description
General warning	A1	Over-regeneration warning
	A3	Fan warning
	A8	External scale error warning
	A9	External scale communication warning
Extended warning	C3	Main power off warning

■ Time characteristics of overload protection

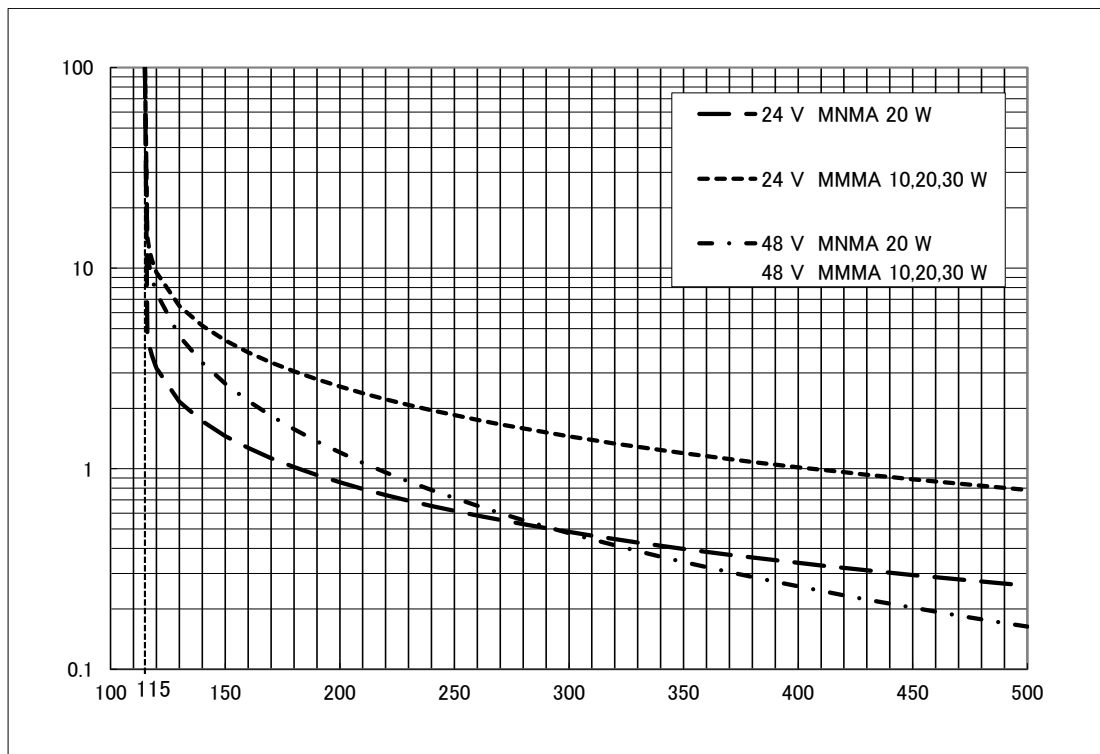

The above figure is the time characteristics of overload protection of the driver using the MMMA 10, 20, 30 W, and MNMA 20W motor.

- Notes: Use the motor so that actual torque stays in the continuous running range shown in “S-T characteristic” of the motor.
For the S-T characteristics, see [SPECIFICATIONS] motor characteristics (S-T characteristics).