REFERENCE SPECIFICATIONS

Product Name : AC servo driver
Model Number: MINAS-A5 Series M Size

Issued on
Dec, 7, 2015
Revised on
Apr, 11,2016

Motor Business Unit, Electromechanical Control Business Division
Automotive & Industrial Systems Company, Panasonic Corporation

7-1-1 Morofuku , Daito-City, Osaka 574-0044 Japan
Phone : +86-72-871-1212
Fax : +86-72-870-3151

Contents

- 1. Scope..... 1
- 2. Model Number..... 2
- 3. Applicable Motor..... 2
- 4. Basic Specifications..... 3
- 5. Dimensions..... 4
- 6. Appearance and Part Names 5
- 7. Connectors 6
 - 7-1 Power Supply Connectors **CN102** , **CN103**.....6
 - 7-2 Moter Connector **CN101**.....6
 - 7-3 Encoder Connector **CN104**.....6
 - 7-4 USB Connector **CN7**.....7
 - 7-5 RS232/RS485 Connector **CN4**.....8
 - 7-6 I/O Connector **CN1**.....9
- 8. Wiring 13
 - 8-1 Cables and Maximum Lengths13
 - 8-2 Cable Side Connectors13
 - 8-3 Precautions for Wiring14
- 9. Safety Precautions..... 18
- 10. Life and Warranty 22
 - 10-1 Life Expectancy of the Driver.....22
 - 10-2 Warranty Period.....22
- 11. Others 23
 - Specification for Each Model

1. Scope

The specifications are for AC servo driver MINAS-A5 Series M size model made by Motor Business Unit, Automotive & Industrial Systems Company, Panasonic Corporation.

This product is for industrial equipment.
It cannot be used in the general household

<Software version>

This document applies to the servo drivers of the following software version:

Ver.3.10

For the software version, confirm it by the setup support software PANATERM or other function.

<Related documents>

SX-DSV03121: Technical document

<IMPORTANT>

- All rights reserved. No part of this publication may be reproduced or transmitted in any form without prior permission.
- Motor Business Unit, Automotive & Industrial Systems Company, Panasonic Corp. reserves the right to make modifications and improvements to its products and/or documentation, including specifications and software, without prior notice.

Operating Precautions

Pay a special attention to following items in order to prevent failure and degradation of the product.

- Implement the measure against static electricity and handle it with great caution.
- Do not touch a electronic components except the heat sink of the product when installing and carrying it.
- Do not touch edge and corner of the connector and printed-circuit board of the driver.
- When the equipment is energized, do not touch the driver.
- Install in a metal control box in order to prevent malfunction by noises, such as an electromagnetic interference (EMI).
- Prevent foreign matter from getting into the product.
- Do not give an impact shock to the product.
- Do not put a foreign matter into the servo driver.
- Do not add stress, such as a twist and bending, to the printed-circuit board of the product. Fix the cable so that stress is not added to the printed-circuit board and the connector of the product.

2. Model Number

The following shows how to interpret a Model number.

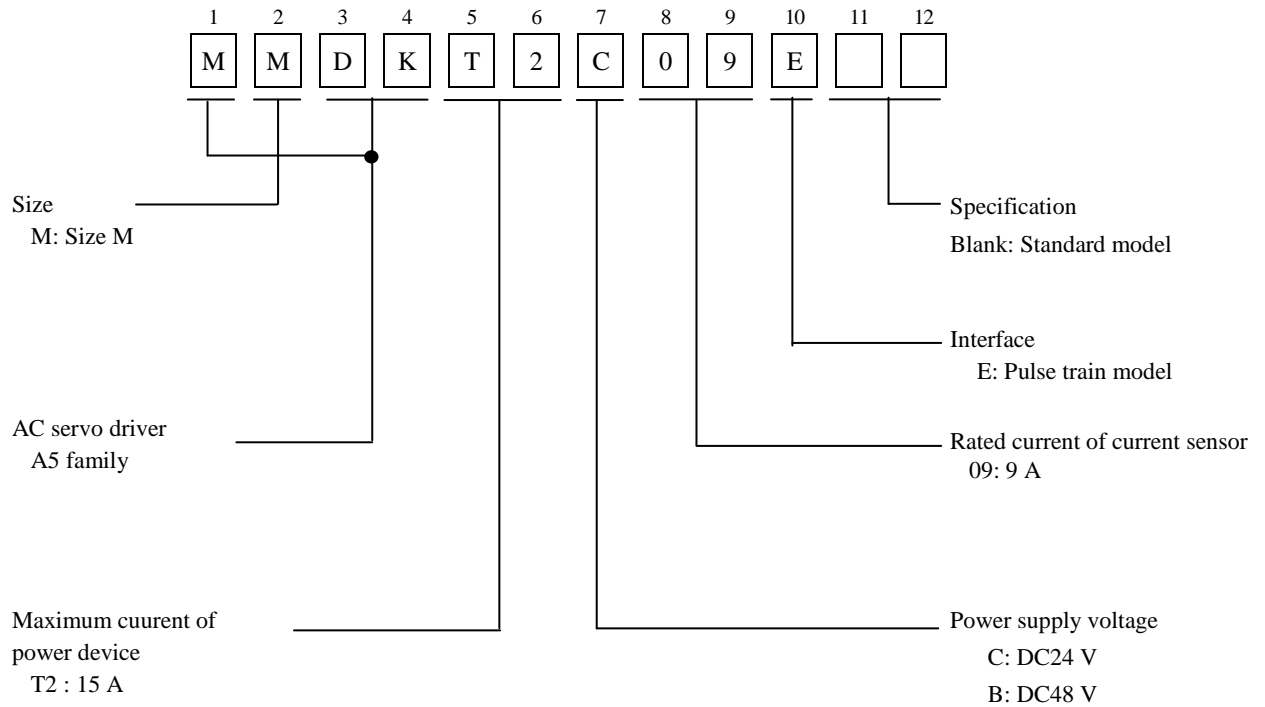

3. Applicable Motor

Driver			Applicable motor			
Model No.	Size	Power Supply	Model No.	Rated power	Rated speed [r/min]	Encoder specification
MMDKT2C09E	M	DC 24 V	MMMA1ACF**	10 W	3000	20 bit absolute encoder
			MMMA2ACF**	20 W	3000	20 bit absolute encoder
			MMMA3ACF**	30 W	3000	20 bit absolute encoder
			MNMA2ACF**	20 W	3000	20 bit absolute encoder
MMDKT2B09E	M	DC 48 V	MMMA1ABF**	10 W	3000	20 bit absolute encoder
			MMMA2ABF**	20 W	3000	20 bit absolute encoder
			MMMA3ABF**	30 W	3000	20 bit absolute encoder
			MNMA2ABF**	20 W	3000	20 bit absolute encoder

4. Basic Specifications

Item			Description		
Input power supply (Note 1)	DC 24 V type	Voltage range		DC24 V +/- 10 %	
		Power capacity	Applicable motor	MMMA 10 W	Rated current : 1.5 A _{rms} Instantaneous maximum current : 13 A _{0-p}
				MMMA 20 W	Rated current : 2.5 A _{rms} Instantaneous maximum current : 11 A _{0-p}
				MMMA 30 W	Rated current : 3.3 A _{rms} Instantaneous maximum current : 12 A _{0-p}
	NMMA 20 W			Rated current : 2.8 A _{rms} Instantaneous maximum current : 14 A _{0-p}	
	DC 48 V type	Voltage range		DC48 V +/- 10 %	
		Power capacity	Applicable motor	MMMA 10 W	Rated current : 0.9 A _{rms} Instantaneous maximum current : 6 A _{0-p}
				MMMA 20 W	Rated current : 1.6 A _{rms} Instantaneous maximum current : 11 A _{0-p}
				MMMA 30 W	Rated current : 1.9 A _{rms} Instantaneous maximum current : 11 A _{0-p}
	MNMA 20 W			Rated current : 1.5 A _{rms} Instantaneous maximum current : 9 A _{0-p}	
Operation conditions		Temperature	Operation temperature: 0 - 55 degrees C Storage temperature: -20 - 65 degrees C Guarantee the maximum temperature: 80 degrees C 72hours		
		Humidity	Operation and storage humidity 20-85 %RH or less (no condensation)		
		Height above the sea	1000 meters or less		
		Vibration	5.88 m/s ² or less, 10-60 Hz Continuous operation at resonance point is not allowed (Note 2)		
Protection rating			IP00 (Note 3)		

* Easier condensation occurs when the temperature is reduced.

(Note 1) DC power using stabilized power supply (SELV) are provided with reinforced insulation.

Do not exceed the voltage including ripple of DC power is supply voltage range of the servo driver.

(Note 2) Do not install in a flexible region.

(Note 3) Protection rating of this servo driver is IP00 (No protection).

Make sure not to put the electric static discharge or the foreign matters such as dust when installing or handling the driver

5. Dimensions

Size M

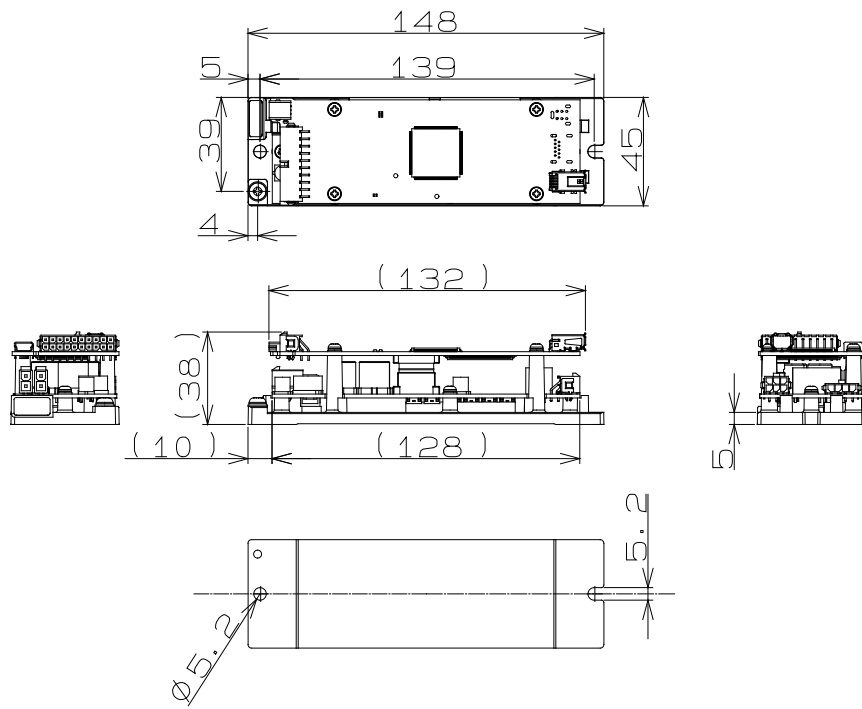

Unit : mm

6. Appearance and Part Names

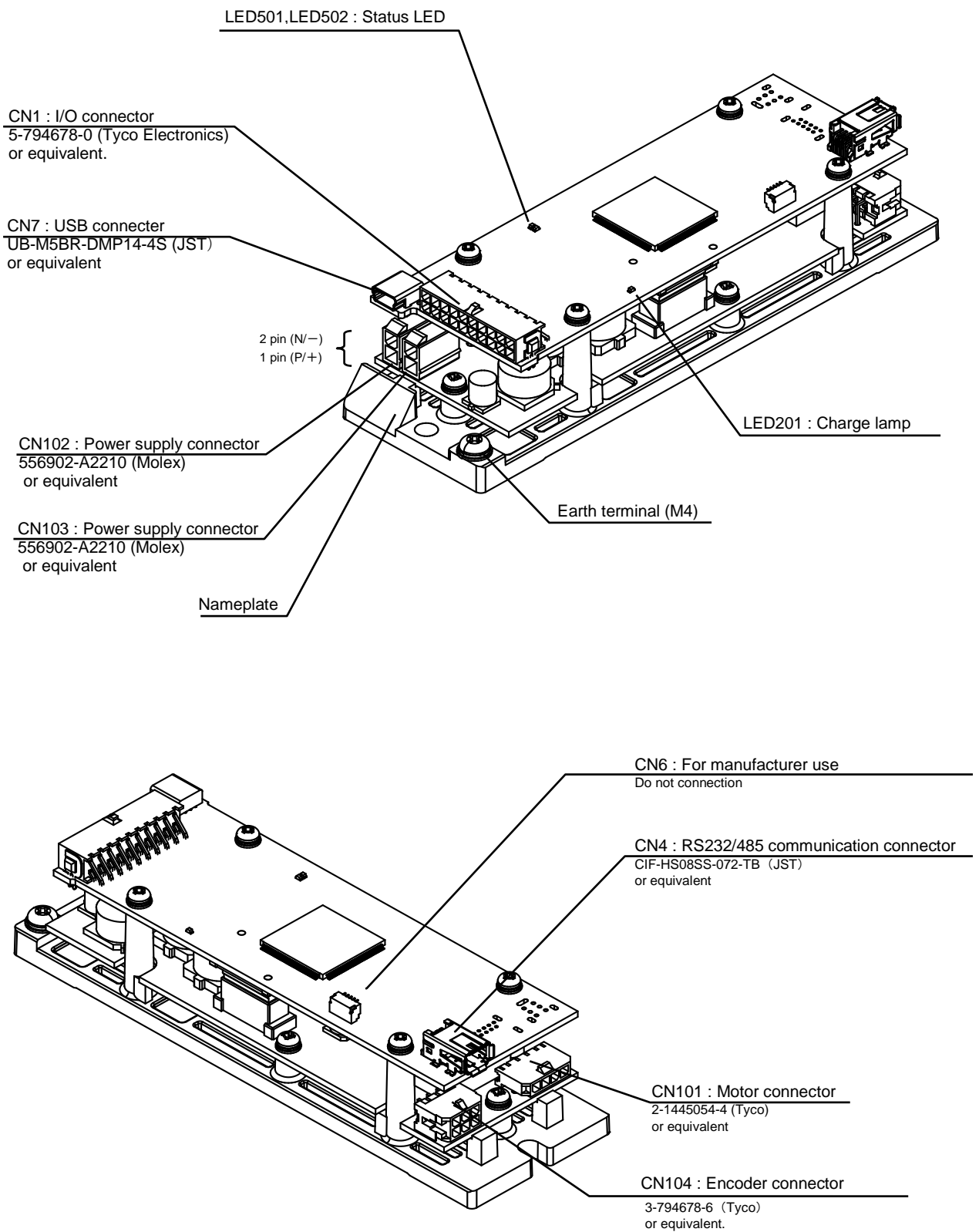

7. Connectors

7-1 Power Supply Connectors CN102, CN103

Servo driver side: Molex 556902-A2210, Plating: TIN (or equivalent)

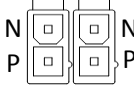
Pin No.	Symbol	Description	Pin location
1	P (+ Line)	<ul style="list-style-type: none"> • Input DC24 V, DC48 V. • DC power source using a stabilized power supply are provided with reinforced insulation. 	
2	N (- Line)		

* There is no anti-reverse connection function on the driver.

Reverse connection is caused of failure.

Pay enough attention to the power supply wiring.

* This servo driver has two power connectors, in order to install two or more daisy chain connection.

In that case, be sure not to exceed the maximum current (9 A) of these connectors.

7-2 Motor Connector CN101

Servo driver side: 2-1445054-4, Plating: TIN (or equivalent)

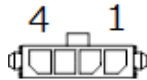
Pin No.	Symbol	Description	Pin location
1	U	Connect U phase of the motor winding	
2	V	Connect V phase of the motor winding	
3	W	Connect W phase of the motor winding	
4	FG	Connect ground wire of the motor	

7-3 Encoder Connector CN104

Servo driver side: Tyco Electronics 3-794678-6, Plating: GOLD (or equivalent)

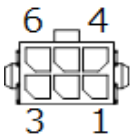
Pin No.	Symbol	Description	Pin location
1	NC	NC (No connection)	
2	PS	Encoder signal input / output (serial signal)	
3	\overline{PS}		
4	E5V	Power supply output	
5	E0V		
6	FG	Frame ground	

7-4 USB Connector CN7

Servo driver side: J. S. T. Mfg. UB-M5BR-DMP14-4S, Plating: GOLD (or equivalent)

By connecting to the PC through USB interface, various operations such as setting / changing of parameters, monitoring of control state, referencing of error/history, and saving/loading of parameters can be performed.

Pin No.	Symbol	Description
1	VBUS	USB communication signal
2	D-	
3	D+	
4	-	NC (No connection)
5	GND	Signal ground

<About the USB cable>

Use a commercial-release USB cable with a ferrite core.

Connector of the servo driver side is a mini-B.

For the connector of a computer side, use it united with the specification of the computer to be used.

7-5 RS232/RS485 Connector CN4

Servo driver side: J. S. T. Mfg. CIF-HS08SS-072-TB equivalent, Plating: GOLD (or equivalent)

Pin No.	Symbol	Name	Description
1	GND	Signal ground	• Signal ground
2	-	NC	• Do not connect
3	TXD	RS232 signal	• Serial Bus transmission and reception data (RS232)
4	RXD		
5	485-	RS485 signal	• Serial Bus transmission and reception data (RS485)
7			
6	485+		
8			
Shell	FG	Frame ground	• Frame ground

7-6 I/O Connector **CN1**

Servo driver side: Tyco Electronics. 5-794678-0, Plating: GOLD (or equivalent)

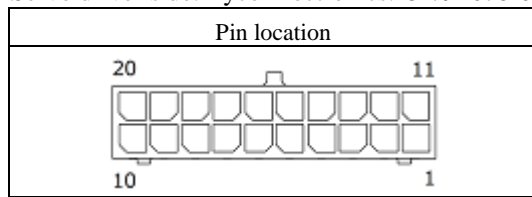
**Input**

Pin No.	Name	Symbol	Description	I/O type
1	Power supply input	COM+	<ul style="list-style-type: none"> Connect to the + terminal of an external DC power supply (12 to 24 V) Use a 12 V (+/- 5 %) to 24 V (+/- 5 %) power supply 	-
2	Multi-function input 1	SI1	<ul style="list-style-type: none"> The function changes according to the parameter settings. See below. 	i-1
9	Multi-function input 4	SI4		
7	Multi-function input 7	SI7		
8	Multi-function input 10	SI10		

Functions allocatable to Multi-function inputs

Name	Symbol	Description
Servo ON	SRV-ON	<ul style="list-style-type: none"> When turned ON, the servo is turned on (power is supplied to the motor). When turned OFF, the servo is turned off and the motor power is turned off.
Control mode switch	C-MODE	<ul style="list-style-type: none"> Switches the control modes.
Positive overtravel limit	POT	<ul style="list-style-type: none"> Positive overtravel limit. Make sure to connect this so that the contact point will be opened when the movable module positively exceeded the movable range. When this input is OFF, a positive torque does not occur.
Negative overtravel limit	NOT	<ul style="list-style-type: none"> Negative overtravel limit. Make sure to wire this input to be activated as the work over travels the limit in the negative direction. When this input is OFF, a negative torque does not occur.
Deviation counter clear	CL	<ul style="list-style-type: none"> Clears the position deviation counter.
Command pulse inhibition	INH	<ul style="list-style-type: none"> Ignores the position command pulse.
Preset velocity 1	INTSPD1	<ul style="list-style-type: none"> Preset speed. Allows you to set up to 8 internal velocities by combining INTSPDs 1 - 3.
Preset velocity 2	INTSPD2	
Preset velocity 3	INTSPD3	
Speed zero clamp	ZEROSPD	<ul style="list-style-type: none"> Sets the speed command to zero.
Anti-vibration switch 1	VS-SEL1	<ul style="list-style-type: none"> Switches the applied frequencies for anti-vibration control.
Anti-vibration switch 2	VS-SEL2	
Gain switch	GAIN	<ul style="list-style-type: none"> Input to switch the gains.
Torque limit switch	TL-SEL	<ul style="list-style-type: none"> Switches the torque limits.
Alarm clear	A-CLR	<ul style="list-style-type: none"> Digital input to clear the alarm.
Command scaling switch	VC-SIGN	<ul style="list-style-type: none"> Specifies the sign of the speed command during the speed control.
Torque command sign	TC-SIGN	<ul style="list-style-type: none"> Do not use.
Command scaling switch 1	DIV1	<ul style="list-style-type: none"> Switches the scaling numerators of the command pulse. Allows you to switch up to 4 numerators by combining DIVs 1, 2.
Command scaling switch 2	DIV2	
Forced alarm input	E-STOP	<ul style="list-style-type: none"> Generates Err87. 0 "Abnormal forced alarm input."
Inertia ratio switch	J-SEL	<ul style="list-style-type: none"> Switches the inertia ratios.

"Deviation counter clear (CL)" can only be assigned to the SI7.

"Command pulse inhibition(INH)" can only be assigned to the SI10.

Input signals (command pulse train) and their functions

A suitable interface can be chosen from “A. Pulse train interface with line driver” .

A. Pulse train interface with line driver

Pin No.	Symbol	Name	Description	Circuit
3	PULSH1	Command pulse input 1	<ul style="list-style-type: none"> • Input terminal for the position command pulse. It can be selected by setting corresponding parameters. • Disabled in such control modes as the speed control or the torque control, which does not require position commands. • The maximum allowable input frequency is 4 Mpps. 	Di-2
4	PULSH2			
5	SIGNH1	Command direction input 1		
6	SIGNH2			

Output

Pin No.	Symbol	Name	Description	Circuit
11	SO1	Multi-function output 1	• The function changes according to the parameter settings. See below.	o-1
10	SO2	Multi-function output 2		
12	COM-	Power supply input	<ul style="list-style-type: none"> • Connect to the + terminal of an external DC power supply (12 to 24 V) • The power capacity varies depending on a composition of I/O circuit. 0.5 A or more is recommended. 	—

Functions allocatable to Multi-function outputs

Name	Symbol	Description
Servo Alarm	ALM	• Digital output to indicate the drive is in alarm status..
Servo ready	S-RDY	• Digital output to indicate the drive is ready to be enabled.
Motor holding break release	BRK-OFF	• Digital output to provide the timing signal to control the motor holding brake.
Zero speed	ZSP	• Outputs the zero speed detection signals.
Torque limited	TLC	• Outputs the torque limit signal.
In-position	INP	• Outputs the positioning completion signal.
Positioning completion 2	INP2	• Outputs the positioning completion signal 2.
At speed	AT-SPD	• Outputs the at-speed signal.
V-COIN	V-COIN	• Outputs the speed coincidence signal.
Warning output 1	WARN1	• Outputs the warning output signal configured in Pr4. 40 "Warning output selection 1".
Warning output 2	WARN2	• Outputs the warning output signal configured in Pr4. 41 "Warning output selection 2".
Position command ON/OFF	P-CMD	• Outputs meaning positional command applied.
Speed in –limit output	V-LIMIT	• Outputs meaning the speed is limited at torque control mode.
Alarm attribute output	ALM-ATB	• Outputs meaning occur an alarm that can be cleared.
Servo on status output	SRV-ST	• Turns on output transistor when servo is on.

Output signals (Pulse output) and its function

Pin No.	Symbol	Name	Description	Circuit
14	OA+	A phase output	<ul style="list-style-type: none"> • Scaling processed encoder signal or external scale signal (A/B/Z-phase) is output in differential mode. (RS422 equivalent) • Scaling ratio can be set by parameters. • The ground pin of the line driver on the output circuit is not insulated and is connected to signal ground (GND). • The maximum output frequency is 4 Mpps (after quadrature). 	Do-1
15	OA-			
16	OB+	B phase output		
17	OB-			
18	OZ+	Z phase output		
19	OZ-			

8. Wiring

8-1 Cables and Maximum Lengths

Name	Symbol	Maximum cable length	Cable
Power connection	CN102 CN103	-	AWG 18
Motor connection	CN101	3 m	AWG 20
Encoder connection	CN104	3 m	Overall twisted shielded pair Core wire: 0.18 mm ² or larger
I/O connection	CN1	1 m	AWG 26-28

8-2 Cable Side Connectors

Symbol	Part name	Part number	Manufacturer
CN102 CN103	Connector	5557-02R	Molex
	Pin	5556TL	
CN101	Connector	1445022-4	Tyco Electronics
	Pin	794610-1	
	Connector	43645-0400	Molex
	Pin	43030-0001	
CN104	Connector	794617-6	Tyco Electronics
	Pin	794611-3	
	Connector	43025-0600	Molex
	Pin	43030-0002	
CN1	Connector	2-794617-0	Tyco Electronics
	Pin	794611-3	
CN4	Plug kit	2040008-1	Tyco Electronics

Use connectors listed above or equivalents.

8-3 Precautions for Wiring

(1) Wiring to power connector

- [1] Power connector of the servo driver is tin plated. In order to avoid a bad contact caused by dissimilar metals, connector pins for the connection, please use the tin plating.
- [2] The DC power supply might have a trip to protect its components from over-voltage that is caused by the regenerated energy from motor. In that case, it is necessary to install the diode for protecting from the feedback current and also to install the DC bus capacitor for storing the regenerated energy between the DC power supply and drivers.
- [3] So that the specified voltage at the input servo driver, consider the transient voltage drop due to the impedance wiring, select both the diameter of the power line and the length.
- [4] This servo driver does not mount the inrush current limit circuit. Inrush current is dependent on the characteristics and wiring impedance of the connection power, please check the actual machine.
- [5] Because this servo driver to assume a connection with a stabilized power supply is provided with reinforced insulation, protective ground terminal is not available. M4 screw on the heat-sink is functional earth (FG).

(2) Wiring to motor connector

- [1] Motor connector of the servo driver is tin plated. In order to avoid a bad contact caused by dissimilar metals, connector pins for the connection, please use the tin plating.
- [2] For a noise countermeasure, attach the ferrite core U, V, W as necessary.

(3) Wiring to encoder connector.

- [1] Encoder connector of the servo driver is gold plated. In order to avoid a bad contact caused by dissimilar metals, connector pins for the connection, please use the gold plating.
- [2] Encoder cable is a stranded wire of core wire, please use Collective shield twisted pair cable.
- [3] Maximum cable length is 3 m. In order to meet the mitigation of the voltage drop of 5 V power supply to the encoder to long wiring, select the appropriate wire diameter.
- [4] Cable should be located well away from power cable and motor cable with large current.

(4) Wiring to I/O connector

- [1] I/O connector of the servo driver is gold plated. In order to avoid a bad contact caused by dissimilar metals, connector pins for the connection, please use the gold plating.
- [2] Do not exceed the maximum voltage and current specification of the input and output.

(5) Wiring to connector **CN1**

- [1] The 12–24 VDC power supply for the external control signal connected to the I-COM should be prepared by the customer.
- [2] Place the servo driver and its peripheral device as nearly as possible (up to 3 m) so as to shorten the wiring.
- [3] Wire the wiring as far away as possible (30 cm or more) from the power lines (P, N, U, V, W).
Do not put them in the same duct or bind them together.

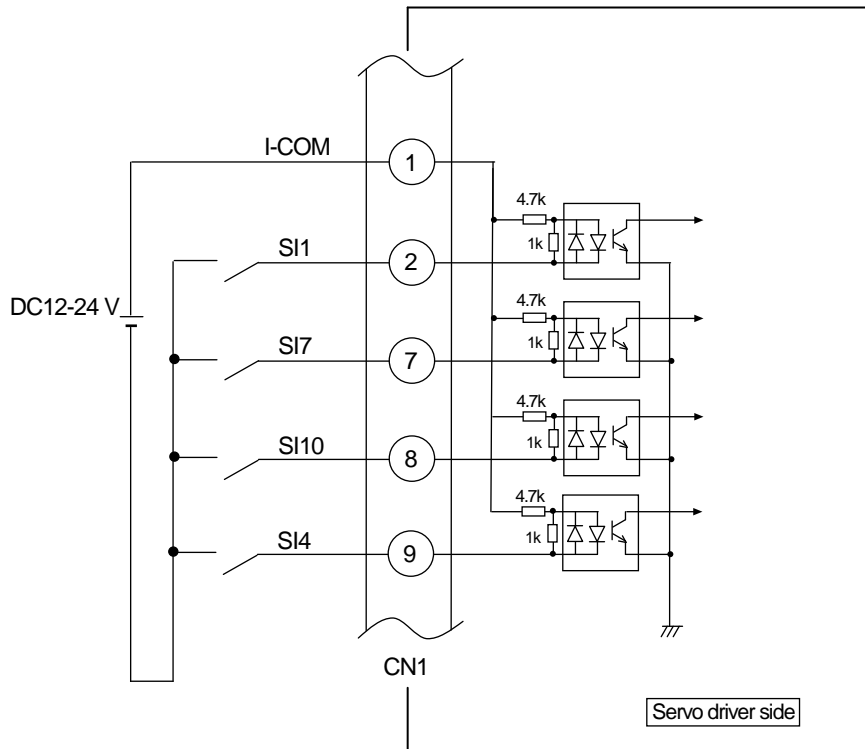
Input

The functions of the pins SI1, SI4, SI7, SI10 are assigned by parameters. For factory default settings, refer to Appendix “Specification for Each Model”.

Output

- [4] Be aware of the polarity of the power supply for control signals. The servo driver is damaged by reverse connection of the polarity shown in the following figure.
- [5] To directly drive the relay with each output signal, make sure to attach a diode in parallel to the relay and in the direction as shown in the figure below. The servo driver can be damaged if the diode is not attached or the diode is attached in the reverse direction.
- [6] Apply 50 mA or less of current to output.

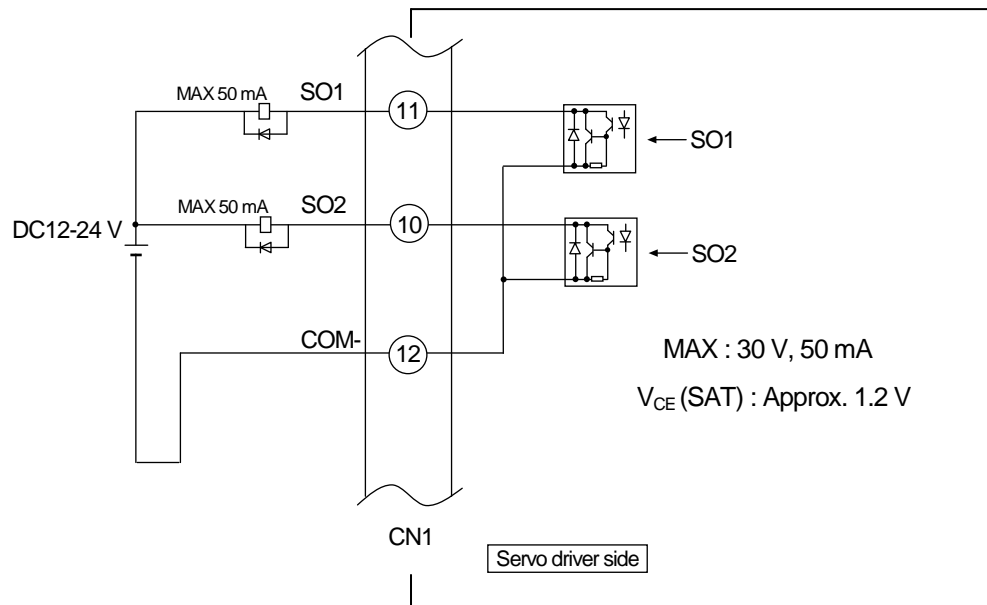

The functions of the pins SO1, SO2 are assigned by parameters. For factory default settings, refer to Appendix “Specification for Each Model”.

(6) Wiring to connector **CN104**

- [1] As for the encoder signal cable, use the batch shielded twisted wire pairs whose core is 0.18 mm² or more.
- [2] The cable length should be up to 3 m. When the wiring is long, we recommend you to use the double wiring for the 5 V power supply in order to reduce the impact of voltage drop.
- [3] Make sure to connect the shield to 6pin (FG) of **CN104**.
- [4] Wire the wiring as far away as possible (30 cm or more) from the power lines (P, N, U, V, W).
Do not put them in the same duct or bind them together.
- [5] Do not connect anything to the empty pins of **CN104**.

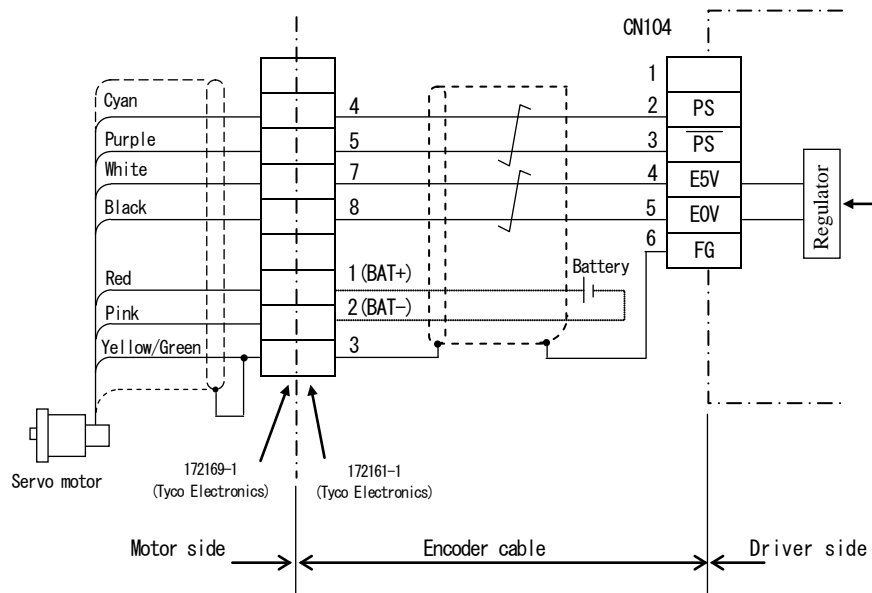

In case of 20bit absolute encoder

If you wish to use in absolute encoder system, the battery for absolute encoder, please directly connected between motor side BAT- and motor side BAT+.



SAFETY PRECAUTIONS

9. Safety Precautions

- Danger and damage caused when the safety precautions are ignored are described in the following categories and signs:

 DANGER	Description of this sign indicates “urgent danger that may cause death or serious injury.”
 CAUTION	Description of this sign indicates “danger that may cause injury or property damage.”

- Rules to keep are categorized and described with the following graphics.

	This graphic indicates “Prohibited” acts that are not permitted.
	This graphic indicates “Mandatory” acts that must be performed forcibly.

DANGER



- (1) Be sure not to store or use the equipment under conditions subjected to vibrations (5.88 m/s² or heavier) or an impact shock, foreign matters such as dust, metal particles oil mist, liquids such as water, oil and polishing liquid, near flammable objects, in an atmosphere of corrosive gas (such as H₂S, SO₂, NO₂, Cl₂), or in an atmosphere of flammable gas.
- (2) Do not place any flammable objects near a motor, a servo driver.
- (3) Do not drive the motor with an external force.
- (4) Do not damage or strain the cable, or do not apply excessive stress. Do not place a heavy item on the cable or do not pinch the cable.
- (5) Do not use the equipment with the cable soaked in oil or water.
- (6) Do not install the equipment near a heating object such as a heater or a large wire-wound resistor. (Install a thermal shield, etc. to avoid the influences of heating object.)
- (7) Do not connect the motor directly with a commercial power.
- (8) Do not use the equipment under conditions subject to strong vibrations or an impact shock.
- (9) Be sure not to touch a rotating part of a motor during operation.
- (10) Please do not touch with bare hands to motor key way.
- (11) Be sure not to touch inside a servo driver.
- (12) Motor, servo driver heat sink and peripheral device become very hot. Do not touch them.
- (13) Do not carry out wiring or do not operate the equipment with wet hands.
- (14) Wiring work is strictly allowed only for an engineer specializing electrical work.



SAFETY PRECAUTIONS



- (15) A motor other than specified is not provided with a protection device. Protect a motor with an overcurrent protection device, a ground-fault interrupter, overheating protection device, and emergency stop device, etc.
- (16) When operating the servo driver after an earthquake, inspect installation conditions of the servo driver and the motor and safety of the equipment to make sure that no fault exists.
- (17) After turning off the power, the inside circuit remains charged at a high voltage for a while. When moving, wiring or inspection the equipment, completely shut off the power supply input outside the servo driver and leave for 15 minutes or longer before working.
- (18) Install and mount the equipment securely to prevent personal injury caused by poor installation or mounting on an earthquake.
- (19) Install an external emergency shutoff circuit to stop operation and interrupt power immediately upon emergency.
Emission of smoke or dust may occur due to a fault of a motor or a servo driver used in combination.
- (20) Mount the motor, the servo driver and the peripheral devices on a noncombustible material such as metal.
- (21) In consideration of strength of the screw and the material of the mounting base, select appropriate fastening torque for the product mounting screws, so that the screws will not be loosened or damaged.
Example) To tighten a steel screw into a steel base : $M5\ 2.7 - 3.3\ N \cdot m$
- (22) Provide correct and secure wiring. Insecure wiring or incorrect wiring may cause runaway or burning of a motor. During wiring work, avoid entry of conductive dust such as wire chippings in a servo driver.
- (23) Connect cables securely and provide secure insulation on current-carrying parts using insulation material.
- (24) FG screw (M4) should be tighten to a torque of $1.0 - 1.2\ N \cdot m$.



CAUTION



- (25) Do not hold cables or motor shaft when carrying the equipment.
- (26) Do not adjust or change servo driver gains extremely, and do not make operations of the machine instable.
- (27) The equipment may suddenly restart after recovery from shutdown upon a power failure. Keep away from the equipment.
Specify settings of the equipment to secure safety for human against such restart operations.
- (28) When the equipment is energized, keep away from the motor and mechanism driven by the motor in case of malfunction.
- (29) Avoid a strong shock to the motor shaft.
- (30) Avoid a strong shock to the product.
- (31) Be sure not to use the electromagnetic contactor installed on the power supply to start or stop the motor.
- (32) Avoid frequent switching on and off the main power supply of the servo driver.
- (33) The built-in brake of the motor is used for holding only. Do not use the brake to stop (braking) for securing safety of the equipment.
- (34) Do not fall or topple over the equipment when carrying or installing.



SAFETY PRECAUTIONS



CAUTION



- (35) Do not climb the motor or do not place a heavy item on the motor.
- (36) Do not put a foreign matter into the servo driver.
- (37) Do not use the equipment under direct sunlight. When storing the equipment, avoid direct sunlight and store under conditions of operating temperatures and humidity.
- (38) Be sure not to disassemble or modify the equipment.
Disassembling and repair is allowed only for the manufacturer or sales agency authorized by the manufacturer.
- (39) Please use power are provided with reinforced insulation the stabilized power supply (SELV). Do not connect the positive side and the negative side and ground (FG) of the input power of servo driver.
- (40) This servo driver is Built-in type (degree of protection IP00). Please note that during the installation so without applying static electricity. Static electricity is applied to runaway or burning, destruction, and cause of failure.

- (41) Use a motor and a servo driver in combination specified by the manufacturer. A customer shall be responsible for verifying performances and safety of combination with other servo motor.
- (42) A failure of a motor or a combined servo driver may cause burning of motor, or emission of smoke and dust. Take this into consideration when the application of the machine is clean room related.
- (43) Install the equipment adequately in consideration of output and main unit weight.
- (44) Keep the ambient conditions of an installed motor within a range of allowable ambient temperatures and of allowable humidity.
- (45) Install the equipment by specified procedures and in specified orientation.
- (46) Install the devices by keeping specified distances between a servo driver and inside control panel or other devices.
- (47) For a test run, hold down a motor and disconnect from a mechanical system to verify operations before installing on the equipmen
- (48) Verify that an input power supply voltage satisfies the servo driver specifications before turning on the power and start operation. An input voltage higher than rated may cause ignition and smoking in the servo driver, which may cause runaway or burning of a motor in some cases.
- (49) When an alarm status occurs, remove a cause of the problem before restarting.
Careless restarting without removing a cause of problem may cause malfunction or burning of a motor.
- (50) The motor may not be able to hold due to expiring useful life or a mechanical structure. Install a braking device on the equipment to secure safety.
- (51) Pay attention to heat radiation. The servo driver generates heat by operating a motor. A servo driver used in a sealed control box may cause an extreme rise of temperature.
Consider cooling so that an ambient temperature around the servo driver satisfies an operating range.
- (52) Maintenance and inspection is allowed only for a specializing person.
- (53) Turn off the power when the equipment is not used for a long term.

- Capacitance of the capacitors of power supply rectifier circuit drops over time. To avoid a secondary problem due to a failure, replacement of capacitors is recommended at an interval of approximately 5 years. Commission the manufacturer or sales agency authorized by the manufacturer to replace the parts.
- Be sure to read the operating manual (safety book) before use.



SAFETY PRECAUTIONS

Servo driver's ambient temperature

The driver's service life significantly depends on the ambient temperature.

Do measures cooling such as fan installation.

Operating temperature range: 0 to 55 degrees C

We have made the best efforts to ensure quality of this product. However, application of external noise (include radiation) or static electricity, or a defect of the input power supply, wiring or components may cause the servo driver to operate beyond the preset conditions. Therefore, you should exercise thorough caution to ensure safety against an unexpected operation.

10. Life and Warranty

10-1 Life Expectancy of the Driver

The Servo driver has 28000 hours of life expectancy when used continuously under the following conditions.

Definition of the life Life end shall be defined as the capacitance of the electrolytic capacitor is reduced by 20 % from the ex-factory status.

Condition	{	Input power source: DC 24 V or DC 48 V Ambient temperature: 55 degree C Output torque: Rated constant value No. of revolutions: Rated constant No. of revolutions
-----------	---	--

Note that the life varies due to the working conditions.

10-2 Warranty Period

(1) Warranty period

For a period of 12 months from the date of delivery or 18 months from the manufacturing month, whichever is shorter.

This warranty shall be exempted in the following cases,

- [1] defects resulting from misuse and/or repair or modification by the customer
- [2] defects resulting from drop of the product or damage during transportation
- [3] defects resulting from improper usage of the product beyond the specifications
- [4] defects resulting from fire, earthquake, lightning, flood, damage from salt, abnormal voltage or other act of God, or other disaster.
- [5] defects resulting from the intrusion of foreign material to the product, such as water, oil or metallic particles.

This warranty shall be exempted when the life of component exceeds its rated standard life.

(2) Warranty scope

Panasonic warrants the replacement of the defected parts of the product or repair of them when the defects of the product occur during the warranty period, and when the defects are under Panasonic responsibility. This warranty only covers the product itself and does not cover any damage incurred by such defects.

11. Others

- Precautions for export of this product and the equipment incorporating this product If the end user or end purpose of this product relates to military affairs, armament and so on, this product may be subject to the export regulations prescribed in “Foreign Exchange and Foreign Trade Control Law”. To export this product, take thorough examination, and follow the required export procedure.
- We cannot warrant this product, if it is used beyond the specified operating conditions.
- Compliance with the relevant standards should be considered by the user.
- The final decision on the compatibility with the installations and components at the user’s site, in terms of structure, dimensions, characteristics and other conditions, should be made by the user.
- When using this product in your equipment, be careful about the compatibility with the servo motor and the servo driver to be used together.
- For performance improvement or other reasons, some components of this product may be modified in a range that satisfies the specifications given in this document.
- Any specification change shall be based on our authorized specifications or the documents presented by the user. If a specification change may affect the functions and characteristics of this product, we will produce a trial product, and conduct examination in advance. Note that the produce price may be changed with a change in its specifications.
- We have made the best efforts to ensure the product quality. However, complete equipment at customer’s site may malfunction due to a failure of this product. Therefore, take precautions by providing fail-safe design at customer’s site, and ensure safety within the operating range of the work place.
- Failure of this product depending on its content, may generate smoke of about one cigarette. Take this into consideration when the application of the machine is clean room related.
- When the equipment runs without connecting the servomotor’s shaft electrically to ground, electrolytic corrosion may occur on the motor bearing and the bearing noise may get louder depending on the equipment and installing environment. So, customer is responsible to check and verify it.
- A customer must verify and inspect the equipment. Please be careful when using in an environment with high concentrations of sulphur or sulphuric gases, as sulphuration can lead to disconnection from the chip resistor or a poor contact connection.
- Take care to avoid inputting a supply voltage which significantly exceeds the rated range to the power supply of this product. Failure to heed this caution may result in damage to the internal parts, causing smoking and/or a fire and other trouble.
- When discard batteries, provide insulation using a tape etc. and discard the batteries abiding by a municipal law.
- When discarding the equipment, process the item as an industrial waste.
- Confirmation of safety and matching of the servo amplifier and motor, execute the responsibility of your company.
- This production is designed for general industry applications, and is not designed for applications of nuclear plant, aerospace, transportation, medical, various safety equipment, highly clean equipment that involve human lives, or for usage under special environment.

【Exemption clause regarding with distribution of drive specified on this spec.】

- Product responsibility will be owned by the publisher of this specification regarding with the drive on this specification, when product had been supplied to the party which agreed to this specification.
- Product responsibility will not be owned by the publisher of this specification when product had gone through the channel or end user which had not conducted the specification agreement.
- Publisher recommends that the drive is to be supplied with the motor manufacture with its motor, based on this specification being agreed with the motor manufacture.
- Specification is to be agreed with the machine manufacture, when the machine manufacture intends to procure the drive and motor separately.
- When in case the agreement of this specification becomes difficult, then we will supply the drive based on the responsibility of the distributor who has agreed to this specification.
- This specification does not assure the operation of the motor matched to the drive specified by this specification. Publisher does not confirm the matching of the motor to drive, and therefore please take extra care in confirming the matching to the motor by equipment manufacture, distributor, or motor manufacture.
- When an unexpected trouble occurs at the matching of motor, distributor, motor manufacture, and machine manufacture is to correspond the trouble in good faith.

Specification for Each Model

● MINAS-A5 Series Size M

Model	MMDKT2C09E	MMDKT2B09E
Power supply input	DC24 V	DC48 V
Maximum instantaneous output current	15 A	15 A
Maximum continuous output current	9 A	9 A
Regenerative processing function	Unprovided	Unprovided
Auto gain tuning function	Provided	Provided
Dynamic brake function	Provided	Provided
Ambient temperature	0–55 degrees C	0–55 degrees C
Main power supply cable	HVSF 0.75–2.0 mm ²	HVSF 0.75–2.0 mm ²
	AWG 14–18	AWG 14–18
Ground cable	HVSF 2.0 mm ²	HVSF 2.0 mm ²
	AWG 14	AWG 14
Motor cable	HVSF 0.50 mm ²	HVSF 0.50 mm ²
	AWG 20 (5 A rated)	AWG 20 (5 A rated)
Inrush Current	No limit by driver	No limit by driver
Weight	Approx. 0.2 kg	Approx. 0.2 kg
Dimensions	Size M	Size M

I/O connector (CN1) default function allocation

CN1 connector		Default function			
Name	Pin number	Signal name	Default value (): in decimal	Symbol	Logic
SI1	2	Servo ON	00030303h (197379)	SRV-ON	NO contact
SI4	9	Alarm clear	00040404h (65793)	A-CLR	NO contact
SI7	7	Deviation counter clear	00000007h (7)	CL	NO contact
SI10	8	Gain switch	00060606h (394758)	GAIN	NO contact
SO1	11	In-position	00000004h (4)	INP	-
SO2	12	Servo alarm	00010101h (65793)	ALM	-

Differences of Specification

This servo driver differs in the following specification to SX-DSV03121 Technical document.

■Basic Specifications

Control mode		Selectable from the following 3 modes by parameter: [1]position control [2]internal velocity control [3]position/internal velocity control
Encoder feedback		20bit(resolution:1048576) 7-serial incremental encoder
External scale feedback		Not Available
Control signal	Input	Multi-function input x 4 Function of each multi-function input is assigned by the parameter.
	Output	Multi-function output x 2 Function of each multi-function output is assigned by the parameter.
Analogue signal	Input	Not Available
	Output	Not Available
Pulse signal	Input	1 inputs Line driver interface can be connected.
	Output	4 outputs Line driver output for Encoder pulses (A/B/Z signal).
Communication	USB	USB interface to connect to computers for parameter setting or status monitoring.
	RS232	1:1 communication *1
	RS485	1: n communication (max 31) *1
Safety Terminal		Not Available
Front Panel		Not Available
Regeneration		Not Available
Dynamic Brake		Built-in (short U-W)

*1 In the case of size M, A5E** series is equipped with a communication function.

■LED

In case of size M, A5 series does not have the LED panel.

Instead, size M is equipped with LED to check state.

SON

LED		Description
LED502 (Green)	Turn ON	Servo ON
	Turn OFF	Servo OFF

SO3

LED		Description
LED501 (Red)	Turn ON	Alarm
	Turn OFF	Normal

LED (SO3) is the possible to change function in the parameters.

LED (SO3) is set alarm at the default parameter.

This servo driver does not support the following protective and warning functions.

■ Protective functions

Error No.		Description
Main	Sub	
13	1	Main power supply under voltage protection
14	1	IPM error protection
18	0	Over-regeneration load protection
	1	Over-regeneration Tr error protection
25	0	Hybrid deviation excess error protection
28	0	Limit of pulse replay error protection
29	1	Deviation counter overflow protection 1
30	0	Safety detection
50	0	Feedback scale connection error protection
	1	Feedback scale communication error protection
51	0	Feedback scale status 0 error protection
	1	Feedback scale status 1 error protection
	2	Feedback scale status 2 error protection
	3	Feedback scale status 3 error protection
	4	Feedback scale status 4 error protection
	5	Feedback scale status 5 error protection
55	0	A-phase connection error protection
	1	B-phase connection error protection
	2	Z-phase connection error protection
92	1	Feedback scale data restoration.
93	2	Parameter setting error protection 2
	3	Feedback scale abnormal connection error protection

■ Warning functions

	Warning No. (Hex.)	Description
General warning	A1	Over-regeneration warning
	A3	Fan warning
	A8	External scale error alarm
	A9	External scale communication alarm
Extended warning	C3	Main power off warning

■ Time characteristics of overload protection

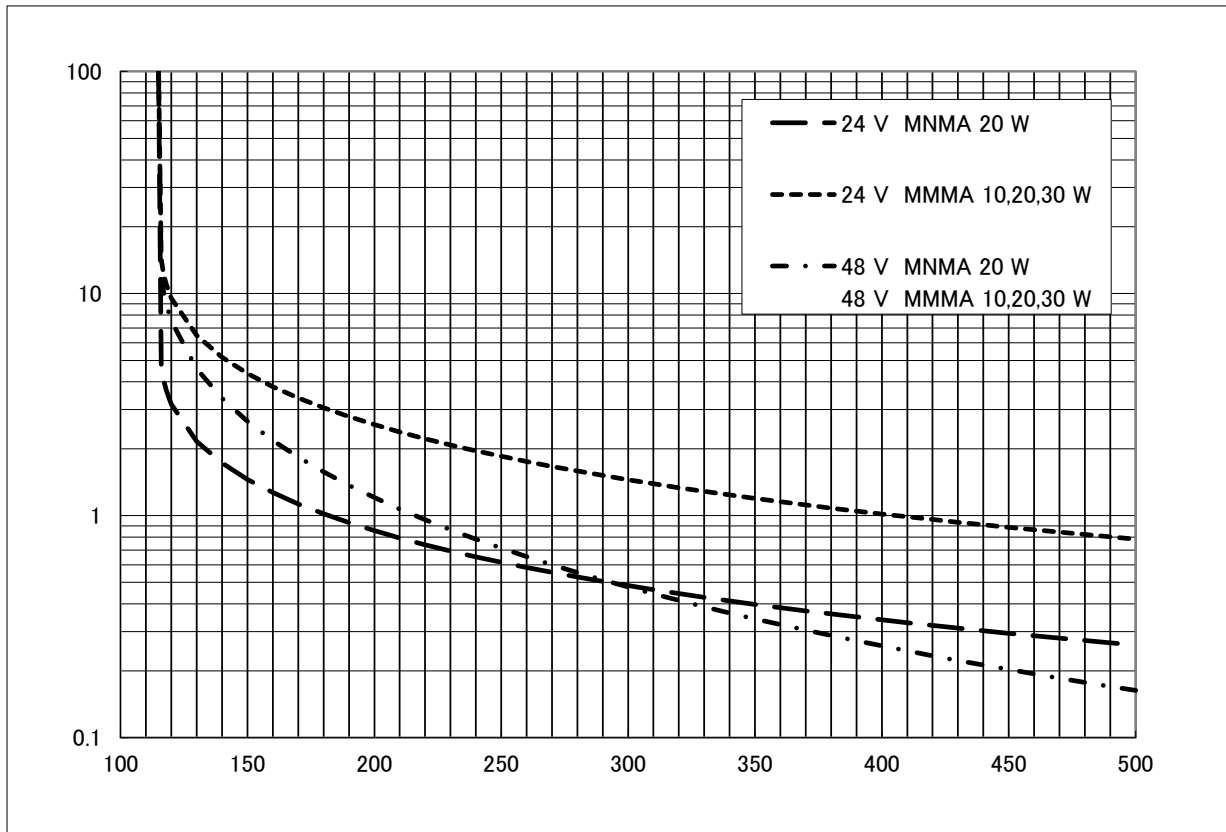

The above drawing describes time characteristics of driver of overload protection at using MMMA 10W motor, 20 W motor, 30 W motor and MNMA 20 W motor.

* Use the motor so that actual torque stays in the continuous running range shown in “S-T characteristic” of the motor.
For the S-T characteristics, see Specification of the motor..