

**Control Unit Exclusive for Light Curtain
SF-C11**

MJE-SFC11 No.0067-40V

Thank you very much for purchasing Panasonic products. Please read this Instruction Manual carefully and thoroughly for the correct and optimum use of this product. Kindly keep this manual in a convenient place for quick reference. English and Japanese are original instructions.

Certain restrictions apply when using the product as a safety device for press machines in Japan. For details, refer to the manual for the light curtain you will be using with the press machine.

1 OUTLINE

- This product is a control unit exclusive for the light curtain conforming to European / North American safety standards and Japanese safety standards for press machines.
 - This device complies with the following standards / regulations.
 - <EU Directives>
EU Machinery Directive 2006/42/EC
EMC Directive 2014/30/EU
RoHS Directive 2011/65/EU
 - <European Standards>
EN 61496-1 (Type 4), EN 55011, EN 50178
EN ISO 13849-1: 2015 (Category 4, PLe)
 - <International Standards>
IEC 61496-1 (Type 4), ISO 13849-1: 2015 (Category 4, PLe)
 - <Japanese Industrial Standards (JIS)>
JIS B 9704-1 (Type 4), JIS B 9705-1 (Category 4)
 - <Standards in US / Canada>
ANSI/UL 61496-1 (Type 4), ANSI/UL 508, UL 1998 (Class 2)
CAN/CSA C22.2 No. 14, CAN/CSA C22.2 No. 0.8
 - <Regulations in US>
OSHA 1910.212, OSHA 1910.217(C), ANSI B11.1 to B11.19
ANSI/RIA 15.06
- Regarding EU Machinery Directive, a Notified Body, TÜV SÜD, has certified with the type examination certificate. With regard to the standards in US / Canada, a NRTL, UL (Underwriters Laboratories Inc.) has certified for cULus Listing Mark.

<Regulations in Korea>
S1-G-35-2005, S2-W-11-2003
The S-mark certificate has been certified by Korea Occupational Safety & Health Agency (KOSHA).

<Reference>
The conformity to JIS, OSHA and ANSI for this device has been evaluated by ourselves.

- The light curtains that can be used in combination with this product are as follows.
SF4D series, SF4B<V2> series and SF2B series

2 FUNCTIONAL DESCRIPTION

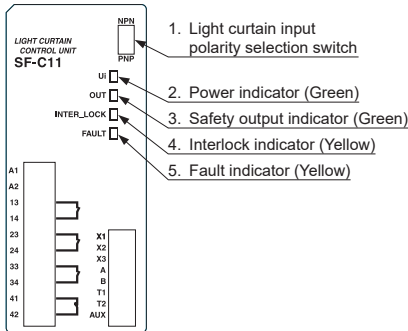

No.	Designation	Description
1	Light curtain input polarity selection switch	Switches to plus grounding or minus grounding.
2	Power indicator (Ui) (Green)	Lights up when the power is supplied.
3	Safety output indicator (OUT) (Green)	Lights up when the safety output is "close."
4	Interlock indicator (INTER_LOCK) (Yellow)	Lights up when the safety output is "open."
5	Fault indicator (FALUT) (Yellow)	Blinks when an error occurs. For details, refer to "TROUBLESHOOTING."

3 INSTALLATION POSITION / DIRECTION / METHOD

- Use the 35mm width DIN rail to install the unit.
- The installation position / direction is not basically limited.
- Please fix this product with the DIN rail stopper **MS-DIN-E** (optional) after installing the product on to the 35mm width DIN rail.
- If two or more units are placed side by side, make sure to space them at least 5mm apart. In case they are mounted close to each other, lower the rated operation current of the safety output depending on the ambient temperature, referring the right graph.
- Always install this product in a control panel having an IP54 or higher protective structure.

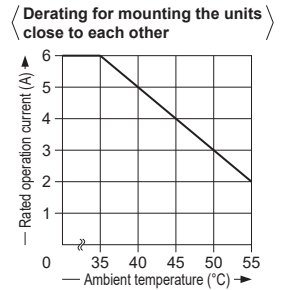

4 I/O CIRCUIT DIAGRAMS

The following cables are recommended for power supply / output line and signal line.
Power supply / output line side: 0.2 to 2.5mm² (AWG 24 to 12)
Signal line side: 0.2 to 1.5mm² (AWG 24 to 16)

<Wiring for the minus grounding (PNP setting)>

- Set the light curtain input polarity selection switch to PNP side and ground the 0V.

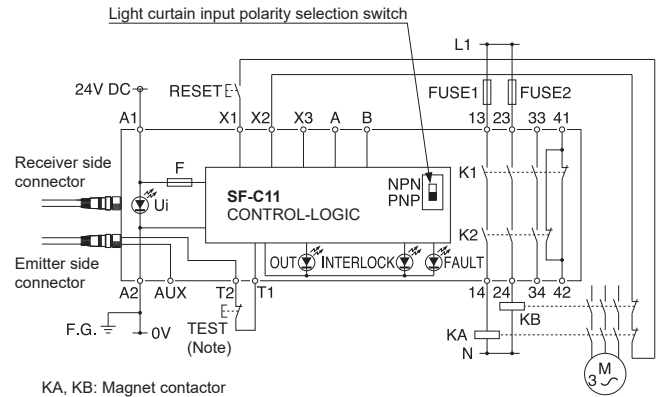

KA, KB: Magnet contactor
Note: Emission halt occurs when the test (TEST) button is open, and emission occurs when the test (TEST) button is short-circuited. If not using the test (TEST) button, short-circuit T1 and T2.

<Wiring for the plus grounding (NPN setting)>

- Set the light curtain input polarity selection switch to NPN side and ground the 24V DC.

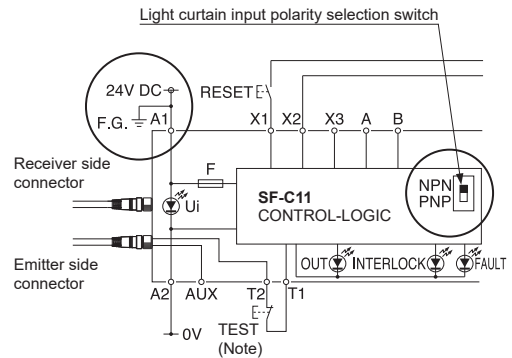

Note: Emission halt occurs when the test (TEST) button is open, and emission occurs when the test (TEST) button is short-circuited. If not using the test (TEST) button, short-circuit T1 and T2.

WARNING

Install a RESET switch in place where it is possible to see all over the dangerous zone and outside of the zone.

<Manual reset>

- In case of the manual reset, configure the back check circuit between X1 and X2. If it is not necessary to check KA and KB, short-circuit KA and KB.
- Do not connect anything to X3.
- The unit operates by the trailing operation of the external reset button.
- Two or more units cannot be controlled by an external reset button. Prepare the external reset button by each unit

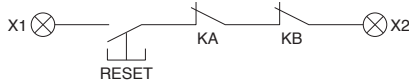

<Auto reset>

- In case of the auto reset, configure the back check circuit between X1 and X3. If it is not necessary to check KA and KB, short-circuit between X1 and X3.
- Do not connect anything to X2.
- Avoid auto-reset of the system after emergency stop by using the other control circuit. (IEC / EN 60204-1 part 9.2.5.4.2 and 10.8.3)



• Terminal arrangement diagram

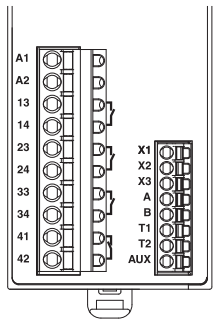

Terminal No.	Description
A1	24V DC
A2	0V
13-14, 23-24, 33-34	Safety output (NO contact × 3)
41-42	Auxiliary output (NC contact × 1)
X1	Reset output terminal
X2	Reset input terminal (manual)
X3	Reset input terminal (automatic)
A	Not used
B	Not used
T1	Test output terminal
T2	Test input terminal
AUX	Light curtain auxiliary output

5 MOUNTING TERMINAL BLOCK

- When connecting to the terminal block, insert a solid wire or twisted wire (lead wire) with a ferrule (sleeve) terminal (please arrange separately) into the hole till it stops as shown in the figure right. The wire is locked when it is properly inserted. However, do not pull the wire with excessive force, as this can cause a cable break.
- When connecting the twisted wire (lead wire) without a ferrule (sleeve) terminal, insert the wire to the innermost of the connecting hole while pressing the release button.
- When releasing the solid wire or the twisted wire (lead wire), pull the wire while pressing the release button.
- The following solid wire and twisted wire (lead wire) are recommended. Power supply / output line side: 0.2 to 2.5mm² (AWG 24 to 12) Signal line side: 0.2 to 1.5mm² (AWG 24 to 16)

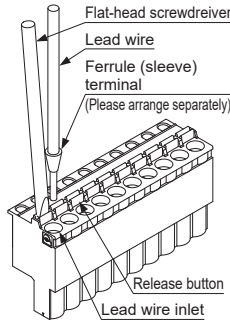

6 SHORT-CIRCUIT PROTECTION

- The power supply unit of this equipment adopts the electronic fuse which do not require any replacement.
- When the electronic fuse is operated, turn OFF the power supply, and remove the cause of overcurrent before restarting the power supply for resetting.
- The electronic fuse is not suitable to use in which the equipment is operated continuously or daily. Note that operating the equipment continuously may be unable to satisfy the specifications.

7 FUNCTIONS

- **Polarity selection function**
 - This is the function to switch either plus grounding or minus grounding with the light curtain input polarity selection switch. When the polarity selection switch is set to "PNP" side, minus grounding is selected and set to "NPN" side, plus grounding is selected.
- **Trailing edge switching function**
 - This function is to accept the input when the reset switch is pressed (contact "close") and then released (contact "open") at the manual start setting. An unexpected start-up due to the welded reset switch can be avoided.

8 MAINTENANCE

- Be sure to do maintenance before use and 6 month periodic maintenance. Refer included instruction manual of light curtain for the inspection items.
- In case replacing this device to new this device, be sure special technician to exchange it. And do daily maintenance and periodic maintenance.

9 USING THIS PRODUCT AS A SAFETY EQUIPMENT FOR A PRESS MACHINE IN JAPAN

When using this product as a safety equipment for a press machine in Japan, this product's installation, electrical wiring, inspection and maintenance must be completed by a "qualified personnel." Qualified personnel refers to a press work supervisor, or other work supervisor who has completed special training as set forth by Industrial Safety and Health Laws, and has extensive knowledge and experience to resolve problems and any problems related to his / her duties.

- When used in combination with **SF4D-□-01 / SF4B-□-01<V2>**, this product satisfies the "Model Examination" as set forth in the Japanese Industrial Safety and Health Laws Provision 44-2 as indicated below.

<Model examination No.>

Light curtain	Control unit	Model examination number
SF4D-F□-01, SF4D-H□-01	SF-C11	TA605
SF4D-A□-01		TA604
SF4B-F□-01<V2>, SF4B-H□-01<V2>		TA526
SF4B-A□-01<V2>		TA525

- Conforming standards: Standards for press machine or shear safety equipment structure (Ministry of Labor Notice No. 102, issued September 21, 1978)
- When using **SF4D-□-01 / SF4B-□-01<V2>** and this product as safety equipments for a press machine in Japan, a pre-work inspection and periodic inspection must be carried out by the press machine work supervisor or by the person in charge of the matters listed in Provision 134, No. 1, 2 and 4 of the Ordinance on Labor Safety and Hygiene. The press machine work supervisor, etc., must inspect the following matters before starting work, and must record and save the results.

Emitter of SF4D-□-01 / SF4B-□-01<V2>

- Security of mounting
- Adequacy of mounting position (safety distance and vertical position)
- Presence of damage
- Presence of abnormality in external wires
- Presence of contamination on emitter
- Security of detection state

Receiver of SF4D-□-01 / SF4B-□-01<V2>

- Security of mounting
- Adequacy of mounting position (safety distance and vertical position)
- Presence of damage
- Presence of abnormality in external wires
- Presence of contamination on receiver
- Security of detection state

Control unit SF-C11

- External wiring
- Indicators
- Presence of abnormal operation with switches, etc.
- Security of mounting

For details, refer to "About the Revision of the Safety Device Management Guidelines for Press Machines" (Ministry of Health, Labour and Welfare Publication 0930 No. 11, September 30, 2015).

• Compatible press machines

- When using this product as a safety equipment for a press machine in Japan, the machine in which **SF4D-□-01 / SF4B-□-01<V2>** and this product are mounted must be capable of suddenly stopping from any operation point even during the operation cycle. Do not use **SF4D-□-01 / SF4B-□-01<V2>** and this product with a machine having an irregular sudden stop.
- Do not use this product with a power press having a full-rotation clutch.
- When using this product as a safety equipment for a press machine in Japan, do not use the product with a press machine that does not satisfy the following specifications.

Item	Specifications
Model	Press machine having sudden stop device and restart prevention mechanism
Pressure capacity	50,000kN or less
Sudden stop time	500ms or less
Stroke length	Within (Protective height - Die height)
Range of model height	Within bolster width

10 TROUBLESHOOTING

- The number of times the fault indicator (yellow) blinks indicates the type of error state, as follows.

Blinking	Description of error	Cause / Remedy
2 times	Internal relay contact is weld	The contact was weld due to the lifetime of the relay. Replace this product by new one.
3 times	Reset mode error	Wiring of the terminal X1, X2 or X3 is not correct. Check if the wiring has been correctly done.
4 times	Type 2 / Type 4 setting error	Do not connect anything to terminal A and B.
5 times	PNP / NPN setting error	The setting of the light curtain input polarity selection switch was changed while the power was ON. Change the setting after the power is turned OFF.
6 times or more	Influence of noise / power supply or internal circuit failure	Check the noise environment. Check the wiring, power supply voltage and voltage capacity.

- When the sensor doesn't operate properly even if the remedies described above are taken, contact our office.
- Interval of blinking for the fault indicator (yellow) is approx. 0.6 sec. Check the number of times the indicator blinks for approx. 2 sec. from the indicator "OFF" period.

11 SPECIFICATIONS

Model No.	SF-C11	
Item		
Connectable input device	SF4D series, SF4B<V2> series, SF2B series	
Applicable standard	EN 61496-1 (Type 4), EN 55011, EN ISO 13849-1: 2015 (Category 4, PL _e) IEC 61496-1 (Type 4) ISO 13849-1: 2015 (Category 4, PL _e) JIS B 9704-1 (Type 4), JIS B 9705-1 (Category 4) ANSI/UL 61496-1 (Type 4), UL 1998 (Class 2) Ministry of Health, Labour and Welfare model examination certified product No. TA605 (SF4D-F□-01, SF4B-D□-01) No. TA604 (SF4D-A□-01) No. TA526 (SF4B-F□-01<V2>, SF4B-H□-01<V2>) No. TA525 (SF4B-A□-01<V2>)	
Supply voltage	24V DC±10% Ripple P-P 10% or less	
Fuse rating	Built-in electronic fuse, Breaking current: 0.5A or more reset by power supply stop	
Safety output (Note 1)	NO contact × 3	
Rated operation voltage / current	30V DC / 6A, 230V AC / 6A Resistance load (the contact protection for inductive load) Minute current: 10mA or more (at 24V DC)	
Contact protection fuse rating	6A (slow-blow)	
Contact material / contacts	AgSnO, Self cleaning, positively driven	
Contact resistance (Initial value)	100mΩ or less	
Mechanical lifetime	10,000,000 times or more (switching frequency 180 times/min.) (Note 2)	
Electrical lifetime	100,000 times or more (switching frequency 20 times/min. at 230V AC / 3A, resistive load) (Note 2)	
Auxiliary output	Safety relay contact (NC contact) × 1 (interlocked to safety output)	
Rated operation voltage / current	24V DC / 2A, Minute current: 10mA or more (at 24V DC)	
Contact protection fuse rating	2A (slow-blow)	
Light curtain auxiliary output	<PNP output specification> • Maximum source current: 60mA • Applied voltage: same as supply voltage (between the light curtain auxiliary output and +V) • Residual voltage: 2.3V or less (at 60mA source current) • Leak current: 2mA or less <NPN output specification> • Maximum sink current: 60mA • Applied voltage: same as supply voltage (between the light curtain auxiliary output and 0V) • Residual voltage: 1.5V or less (at 60mA sink current) • Leak current: 2mA or less	
Output operation	Dark-ON	
Current consumption	100mA or less (without light curtain)	
Application category	AC-15, DC-13 (IEC 60947-5-1)	
Pick-up delay	80ms or less / 90ms or less (Auto reset / Manual reset)	
Response time (Drop-out delay)	10ms or less	
Environmental resistance	Protection	Enclosure: IP40, Terminal: IP20 (This product must be installed into a control box having IP54 construction.)
	Pollution degree	2
	Ambient temperature	-10 to +55°C (No dew condensation or icing allowed) Storage: -25 to +70°C
	Ambient humidity	30 to 85% RH, Storage: 30 to 95% RH
	Vibration resistance	No malfunction when tested with 10 to 55Hz frequency, 0.35mm amplitude in X, Y and Z directions for twenty times each
Overvoltage category	II	
B _{10d} (Note 3)	Minimum load: 20,000,000, Maximum load: 400,000	
Mission time	20 years	
Connection terminal	Detachable spring gauge terminal	
Material	Enclosure: ABS	
Weight	Approx. 320g	

Notes: 1) Timing chart of the safety output is diagram below.

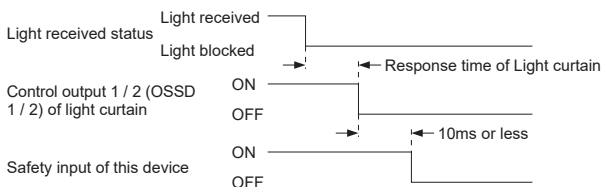

2) The lifetime of the switch of relay depends on type of the load, frequency of switching or environment etc.

3) Mean cycle time that 10% of parts reach dangerous failure.

12 CAUTIONS

- This product has been developed / produced for industrial use only.
- Make sure that the power is OFF while wiring.
- Take care that wrong wiring will damage the product.
- Verify that the supply voltage variation is within the rating.
- Take care that if a voltage exceeding the rated range is applied, or if an AC power supply is directly connected, the product may get burnt or damaged.
- The DC power supply unit must satisfy the conditions given below:
 - 1) Power supply unit authorized in the region where this device is to be used.
 - 2) Power supply unit SELV (safety extra low voltage) / PELV (protected extra low voltage) conforming to EMC Directive and Low-voltage Directive (In case CE Marking conformity is required.)
 - 3) Power supply unit conforming to the Low-voltage Directive and with an output of 100VA or less.

- 4) The frame ground (F.G.) terminal must be connected to ground when using a commercially available switching regulator.
- 5) Power supply unit with an output holding time of 20ms or more.
- 6) In case a surge is generated, take countermeasures such as connecting a surge absorber to the origin of the surge.
- 7) Power supply unit corresponding to CLASS 2 (only for requiring cULus Mark conformation).

- Do not run the wires together with high-voltage lines or power lines or put them in the same raceway. This can cause malfunction due to induction.
- Avoid dust, dirt, and steam.
- Take care that the product does not come in contact with water, oil, grease, or organic solvents such as thinner, etc.
- The seal as shown in the drawing on the right is stuck to the engagement point of unit. When the seal is peeled off or broken, this equipment will not be certified as a "Safety equipment" and will not be covered by our guarantee.
- Note that this equipment is applicable only in the control circuit grounded in accordance with IEC 60204-1 and JIS B 9960-1, or in the control circuit in which the insulation monitor unit (ground fault detection unit) is arranged.
- This product is suitable for indoor use only.

Do not open!
If this seal is removed or damaged, the units are not recognized as safety product.

13 DIMENSIONS (Unit: mm)

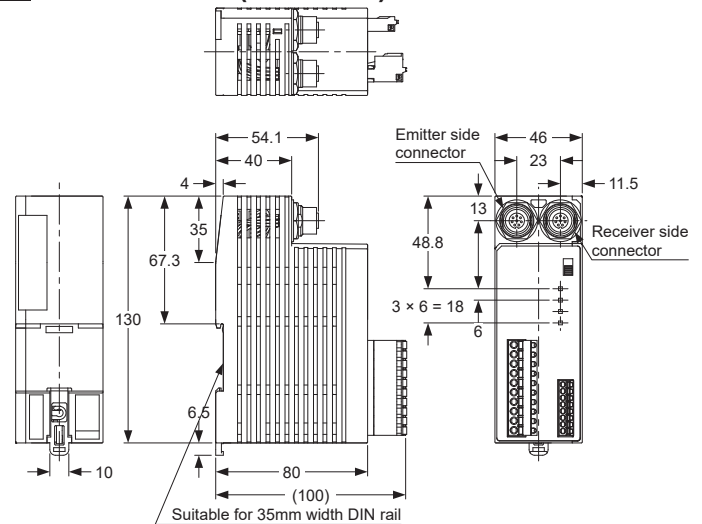

14 INTENDED PRODUCTS FOR CE MARKING

- The model listed under "11 SPECIFICATIONS" comes with CE Marking.
- As for all other models, please contact our office.

15 CE MARKING DECLARATION OF CONFORMITY

Itemized Essentials of EU Declaration of Conformity

Manufacturer's Name: Panasonic Industrial Devices SUNX Co., Ltd.
Manufacturer's Address:
2431-1, Ushiyama-cho, Kasugai, Aichi 486-0901, Japan

EU Representative's Name:
Panasonic Marketing Europe GmbH Panasonic Testing Center
EU Representative's Address: Winsbergring 15, 22525 Hamburg, Germany
Product: Exclusive Control Unit for Light Curtain
Model Name: SF-C10 Series
Trade Name: Panasonic

Application of Council Directive:
- 2006/42/EC Machinery Directive
- 2014/30/EU EMC Directive
- 2011/65/EU RoHS Directive

Harmonized standards:
- EN 61496-1
- EN ISO 13849-1
- EN 55011
- EN 50581

Type Examination: Certified by TÜV SÜD Product Service GmbH
Ridlerstrasse 65 80339 München Germany

Panasonic Industrial Devices SUNX Co., Ltd.

<https://panasonic.net/id/pidsx/global>

Overseas Sales Division (Head Office)
2431-1 Ushiyama-cho, Kasugai-shi, Aichi, 486-0901, Japan
Phone: +81-568-33-7861 FAX: +81-568-33-8591

For sales network, please visit our website.

PRINTED IN JAPAN

© Panasonic Industrial Devices SUNX Co., Ltd. 2019